



HYUNDAI  
SANTA FE  
SPORT

# 9 TERRIFIC USED CAR PICKS

Top-Rated Dishwashers | CONFUSING MEDICAL BILLS? 6 Ways to Protect Yourself

# CR Consumer Reports®

SEPTEMBER 2018

## REVIEWS & RATINGS

- Tesla Model 3
- Generators
- Vacuum Cleaners
- Sound Bars
- Veggie Burgers

# Eat Yourself Healthy



IS IT **SAFE TO EAT** LETTUCE AGAIN?

**BOOST HEART HEALTH** WITH THIS POWER PROTEIN

HOW LEAFY GREENS **KEEP YOU YOUNG**

FRUITS & VEGGIES THAT FIGHT CANCER, **INCREASE ENERGY** & MORE

TIPS TO AFFORD **ORGANIC**

+

**FOOD SAFETY GUIDE**

NEW MEMBERSHIP BENEFIT

# GET THE PERFECT PICTURE ON YOUR TV!



**TV Screen Optimizer™** is the easy way  
to get the best-quality picture on your TV.

Get recommended settings for over 900 models straight from CR's experts  
and improve your TV's image in just minutes.

Check out TV Screen Optimizer™ at [cr.org/membership](https://www.consumerreports.org/membership)

**CR**ConsumerReports™

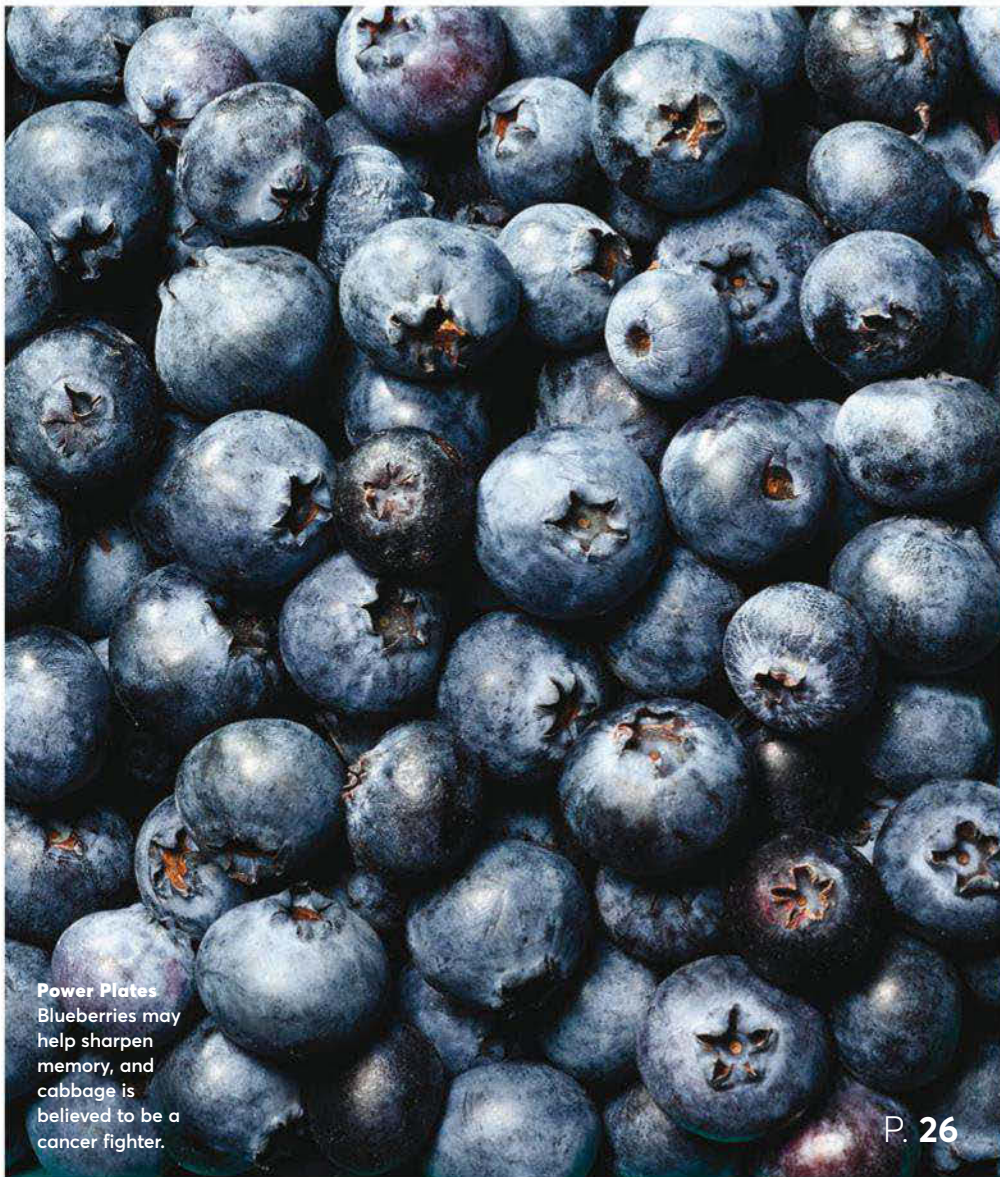

**YOUR FOOD, YOUR HEALTH**

**26 Eat Yourself Healthy**

Is lettuce safe to eat again? How much seafood means too much mercury? Our experts offer solutions to these and other healthy eating concerns.

**Power Plates**  
Blueberries may help sharpen memory, and cabbage is believed to be a cancer fighter.

P. 26

**36 The Dirt on Dishwashers**

Today's appliance is quiet and energy-efficient in addition to cleaning—and you don't need to pay a fortune for one you'll love.

**RATINGS**



**44 Sick of Confusing Medical Bills?**

Learn why our medical billing system is so broken, and what you can do to protect yourself and your family finances before, during, and after a medical procedure.



PHOTO, COVER: SAM KAPLAN/TRUNK ARCHIVE. PHOTOS, TOP LEFT TO RIGHT: TRUNK ARCHIVE; GALLERY STOCK



**Staying Power**  
CR lab testers hook equipment up to generators to determine which will last longest in an outage.

GENERAC  
GP5500 5939

P. 20

IN EVERY ISSUE

**6 From the President: Health Advice You Can Savor**

We're working to improve food safety through our testing, analysis, and investigations.

**7 Building a Better World, Together**

Keeping better track of high-risk foods, fighting cable and other fees, and making credit freezes free of charge.

**8 Your Feedback**

Readers' comments about our recent content.

**19 Recalls**

**66 Index**

**67 Selling It**

Goofs and gaffes.

ROAD REPORT

**53 Ahead of the Curve**

Auto ratings, news, and advice.

**54 Get the Most Used Car for Your Money**

We steer you to the best 2015 cars across categories, including nine notable picks.

**RATINGS**

**63 Road Test**

We test the Hyundai Kona, Lexus LS 500, and two compact electric cars: the Nissan Leaf and Tesla Model 3.

**RATINGS**

HYUNDAI  
KONA



DEPARTMENTS & COLUMNS

**10 What We're Testing in Our Labs ...**

Vacuums, sound bars, pressure washers, TVs, and more.

**RATINGS**



MIELE  
COMPLETE  
C3 MARIN

**12 Ask Our Experts**

Avoiding spare-tire surprises, when to hire a mediator vs. a lawyer, and what curved TVs really have to offer.

**13 CR Insights**

Top-rated veggie burgers, a comparison of music streaming services and prices, and a smart way to save money on gas.

**RATINGS**

PRODUCT UPDATE

**20 More Power to You!**

How to choose and safely use a generator that's right for your home—before the lights go out.

**RATINGS**

**ABOUT CONSUMER REPORTS**

We are the world's largest independent, nonprofit consumer-product-testing organization, based in Yonkers, N.Y. We survey hundreds of thousands of consumers about their experiences with products and services. We pay for all the products we rate. We don't

accept paid advertising. We don't accept free test samples from manufacturers. We do not allow our name or content to be used for any promotional purposes.

**HOW TO REACH US**

Write to us at Consumer Reports, 101 Truman Ave., Yonkers, NY 10703, Attn.: Member Services.

**TO SEND A LETTER TO THE EDITOR**

Go to [CR.org/lettertoeditor](http://CR.org/lettertoeditor).  
**NEWS TIPS AND STORY IDEAS**  
Go to [CR.org/tips](http://CR.org/tips).

**EMAIL SUBMISSIONS**

For Selling It send items to [SellingIt@cro.consumer.org](mailto:SellingIt@cro.consumer.org) or call 800-333-0663. See page 67 for more details.

**ACCOUNT INFORMATION**

Go to [CR.org/magazine](http://CR.org/magazine) or call 800-333-0663. See page 5 for more details.  
**RATINGS** Overall scores are based on a scale of 0 to 100. We rate products using these symbols:  
 ⚠️ POOR    ⚖️ FAIR    🟡 GOOD  
 🟢 VERY GOOD    🟩 EXCELLENT



# Your Gift. Your Legacy. Our Shared Vision.

Your support of Consumer Reports makes our work possible today. Did you know you can have a lasting impact on our future by making a gift in your will?

Together, we can create a fairer, safer, and healthier world.

If you would like more information and our complimentary materials on planning a charitable legacy, please call us at 877-275-3425 or email [legacy@consumer.org](mailto:legacy@consumer.org).



CRM89DEV



**Member Services** You can call us about your membership at 800-333-0663.

**Or write to us:** Consumer Reports Member Services  
P.O. Box 2109, Harlan, IA 51593-0298  
Please include or copy address label from issue.  
(Allow four to six weeks for processing.)

**Visit us online:** [CR.org/magazine](http://CR.org/magazine)

**Use our website to** • Renew or pay for your current magazine • Give a gift • Change your address  
• Report a delivery problem • Cancel your magazine

**Price** In U.S., \$6.99 per issue, special issues \$7.99. In Canada, \$7.99 CAN per issue, special issues \$8.99 CAN (Goods and Services Tax included, GST #127047702). All other countries add \$10 per year to the U.S. price for shipping and handling.

**Back Issues** Single copies of previous 24 issues, \$7.95 each; previous two Buying Guides, \$14.49 each (includes shipping and handling). Please send payment to Consumer Reports, Attn.: Member Services, 101 Truman Ave., Yonkers, NY 10703. Other ways to get Consumer Reports on the go: Google Play, iPad, Kindle, Nook, Readly, Texture, and Zinio.

**Permissions** Reproduction of Consumer Reports in whole or in part is forbidden without prior written permission (and is never permitted for advertising purposes). For questions about noncommercial, educational/academic uses of our content, please submit requests at [CRreprints.com](http://CRreprints.com).

**Mailing Lists** We exchange or rent our print postal mailing list so that it can be provided to other publications, companies, and nonprofit organizations that offer products or services through direct mail. If you wish to have your name deleted from our list, please send your address label with a request for deletion from outside use to Consumer Reports, P.O. Box 2109, Harlan, IA 51593-0298. We do not exchange or rent email addresses. You can review our complete privacy policy regarding Consumer Reports information products, services, and programs at [CR.org/privacy](http://CR.org/privacy).

**Consumer Reports** (ISSN 0010-7174) is published monthly, except twice in December, by Consumer Reports, Inc., 101 Truman Ave., Yonkers, NY 10703. Periodicals postage paid at Yonkers, N.Y., and at other mailing offices; Canadian postage, at Mississauga, Ontario (Canadian publications registration number 2665247, agreement number 40015148). Title Consumer Reports is a federally registered trademark in the U.S. Patent and Trademark Office. Contents of this issue copyright © 2018 by Consumer Reports, Inc. All rights reserved under international and Pan-American copyright conventions.

**CR's No Commercial Use Policy** To view the policy, go to [CR.org/nocommercialuse](http://CR.org/nocommercialuse).

**Contributions** Consumer Reports is an independent 501(c)3 nonprofit organization that works side by side with consumers to create a fairer, safer, and healthier world. Contributions are tax-deductible in accordance with the law. Donations of commonly traded securities or real estate will be accepted and immediately converted to cash. For additional information, email [donorservices@cr.consumer.org](mailto:donorservices@cr.consumer.org). To donate, please send your tax-deductible contribution to Consumer Reports, Attn.: Donor Services, 101 Truman Ave., Yonkers, NY 10703 or go to [CR.org/donate](http://CR.org/donate).

**Charitable Gift Annuity** Establishing a Consumer Reports Charitable Gift Annuity is an ideal way to accomplish your personal financial goals while supporting the mission of Consumer Reports. For additional information, please contact us at 877-275-3425 or [legacy@consumer.org](mailto:legacy@consumer.org).

**Consumer Reports' Staff** operates under contract between Consumer Reports and The NewsGuild of New York Local 31003, CWA.

**Members** Send address changes to Consumer Reports, P.O. Box 2109, Harlan, IA 51593-0298. If the post office alerts us that your magazines are undeliverable, we have no further obligation to fulfill your magazines unless we have a corrected address within two years.

**POSTMASTER** Send all UAA to CFS (see DMM 5071.5.2).

**NON-POSTAL AND MILITARY FACILITIES** Send address corrections to Consumer Reports, P.O. Box 2109, Harlan, IA 51593-0298.

**CANADA POST** If copies are undeliverable, return to Consumer Reports, P.O. Box 481, STN MAIN, Markham, ON L3P 0C4.



Consumer Reports is a member of Consumers International, a federation of more than 220 consumer organizations from more than 115 countries working to protect and empower consumers throughout the world. For information, go to [consumersinternational.org](http://consumersinternational.org).

**Please Remember CR in Your Will** For information about how to make a bequest to Consumer Reports, please contact us at 877-275-3425 or [legacy@consumer.org](mailto:legacy@consumer.org).

# Health Advice You Can Savor



IT SEEMS THAT more and more these days, the dangers we face as consumers are playing out in ways we can't physically see, from online threats to our personal data to what the rise of smart household products will mean for our privacy. So it's no surprise that one of the major topics on consumers' minds today is the integrity of our food system—another part of daily life that can be difficult for us to assess on our own. Of course, what we

eat is one of the most important and personal choices we make every day. That's why this month and in upcoming issues, we'll be working hard to answer your most pressing questions about the health and safety of our food with new testing, investigating, and analysis. It's also why, earlier this year, we led the call for consumers to avoid romaine lettuce after it became clear that it was the likely source of two deadly E. coli outbreaks, and pressed the government to do more to protect us in the future.

As we beef up our food coverage, we're starting with the power of decision-making. Smart choices hold the promise to improve our quality of life across the board by lowering our risk of chronic illnesses, strengthening our hearts, and slowing cognitive decline as we age, yet many of us still shy away from packing our plates with the best ingredients. We're sharing expert tips on how to shop organic without emptying your wallet, along with food-preparation ideas for how any of us can learn to love superpowered foods such as kale. And because even a perfect nutrition regime can't guarantee perfect health, we're also offering guidance on how to avoid unexpected medical bills if you do get sick—because a visit to the doctor should be all about restoring your health, not worrying about being gouged by confusing charges. Ultimately, being well is all about making smart choices, whether in the produce aisle or at the doctor's office—and at CR, smart choices are what we're all about, too.

*Marta Tellado*

**Marta L. Tellado,**  
President and CEO  
Follow me on Twitter  
[@MLTellado](https://twitter.com/MLTellado)

**President and CEO** Marta L. Tellado

**Senior Vice President, Brand & Strategy** Leonora Wiener  
**Vice President, Chief Content Officer** Gwendolyn Bounds

**Editor in Chief** Diane Salvatore  
**Executive Editor** Kevin Doyle

**Features Editor** Natalie van der Meer

**Design Director** Matthew Lenning **Creative Director, Brand** Young Kim  
**Associate Design Director** Mike Smith  
**Manager, Art Operations** Sheri Geller

**Art Directors** Tammy Morton Fernandez, Ewelina Mrowiec, Lisa Slater,  
Michael Solita, Tracy Stora

**Photo Editors** Emilie Harjes, Karen Shinbaum

**Senior Director, Content Development** Glenn Derene  
**Deputy Directors, Content Development** Christopher Kirkpatrick, Ellen Kunes  
**Associate Director, Content Development** Scott Billings  
**Senior Director, Content Impact & Corporate Outreach** Jen Shecter  
**Editorial Director, Digital** Erle Norton  
**Special Projects** Joel Keehn, Director; Lisa Gill, Deputy  
**Senior Director, Product Testing** Mark Connelly

**Cars**

Patrick Olsen, Content Lead  
**Editors:** Keith Barry,  
Jeff S. Bartlett, Jonathan Linkov,  
Mike Monticello, Jeff Plungis  
**Auto Test Center:** Jake Fisher,  
Jennifer Stockburger, Directors  
**Product Testing:** Mike Bloch, Steve  
Elek, Kelly Funkhouser,  
John Ibbotson, Chris Jones,  
Anita Lam, Gene Petersen,  
Ryan Pszczolkowski, Mike Quincy,  
Gabe Shenhar, Shawn Sinclair,  
Emily A. Thomas, Joe Veselak,  
Seung Min "Mel" Yu

**Policy Lead:** David Friedman

**Electronics**

Jerry Beilinson, Content Lead  
**Editors:** Tercius Bufete, Nicholas  
Deleon, Bree Fowler, Thomas  
Germain, Christopher Raymond,  
Allen St. John, James Willcox  
**Product Testing:** Maria Rerech,  
Robert Richter, Testing Leads;  
Elias Arias, Antonette Asedillo,  
Claudio Ciacci, Charles  
Davidman, Richard Fisco,  
Richard Sulin, Maurice Wynn  
**Policy Lead:** Justin Brookman

**Health & Food**

**Editors:** Orly Avitzur, M.D.;  
Julia Calderone; Trisha Calvo;  
Lauren F. Friedman; Chris Hendel;  
Jesse Hirsch; Marvin M. Lipman, M.D.;  
Catherine Roberts; Diane Umansky  
**Product Testing:** Amy Keating,  
Ellen Klosz

**Home & Appliance**

Eric Hagerman, Content Lead  
**Editors:** Mary Farrell, Paul Hope,  
Kimberly Janeway, Sara Morrow,  
Haniya Rae, Daniel Wroclawski  
**Product Testing:** John Galeotafore,  
Emilio Gonzalez, James Nanni,  
Testing Leads; Peter Anzalone,  
John Banta, Susan Booth, Tara  
Casaregola, Lawrence Ciufu, Enrique  
de Paz, Bernard Deitrick, Cindy Fisher,  
Misha Kollontai, Ginny Lui,  
Joan Muratore, Joseph Pacella,  
Christopher Regan, Frank Spinelli,  
Dave Trezza, Michael Visconti

**Money**

Margot Gilman, Content Lead  
**Editors:** Octavio Blanco, Anthony  
Giorgianni, Nikhil Hutheesing, Donna  
Rosato, Tobie Stanger, Penelope Wang  
**Policy Lead:** Anna Laitin

**Chief Scientific Officer** James H. Dickerson

**Food Safety** James Rogers, Director; Sana Mujahid;  
Henry Akinleye, Charlotte Vallaes

**Product Safety** Don Huber, Director; Doris Sullivan, Associate Director

**Content Systems & Operations Strategy** Peter Meirs, Director  
**Content Operations** David Fox, Director; William Breglio; Anthony Terzo  
**Production** Eric W. Norlander, Manager; Letitia Hughes, Terri Kazin

**Imaging** Francisco Collado, Mark Linder

**Content Coordination** Nancy Crowfoot, Associate Director;  
Diane Chesler, Aileen McCluskey

**Copy Editing** Leslie Monthan, Copy Chief;

Noreen Browne, Alison France, Wendy Greenfield

**Fact Checking** David Schipper, Manager; Kathleen Adams, Tracy Anderman,  
Sarah Goralski, Christine Gordon, Sharon MacBride Riley

**Consumer Engagement Testing** Charu Ahuja, Director; Linda Greene, Adam Kaplan  
**Statistics** Michael Saccucci, Director; Andrew Cohen,  
Keith Newsom-Stewart, Martin Romm

**Survey Research** Karen Jaffe, Simon Slater; Dave Gopioian, Kendra Johnson,  
Debra Kalensky, Martin Lachter, Jane Manweiler, Olufemi Olu-Lafe, Adam Troy

**Administration** Decarris Bryant, John McCowen

**Consumer Insight** Monica Liriano, Associate Director;  
Frank Yang; Teneisha Thomas

**Member Support** Sue Melfi, Director; Donna Murianka

**Marketing** Dawn Nelson, Senior Director; Patricia McSorley, Newsstand  
**Procurement Operations** Steven Schiavone, Associate Director

**Vice President, Chief Communications Officer** Matt Anchin; **Vice President,**  
**Financial Planning & Analysis** JoAnne Boyd; **Vice President, Human Resources**  
Lisa Cribari; **Vice President, Data & Marketing Operations** Brent Diamond;  
**Vice President, Chief Digital Officer** Jason Fox; **Vice President, General Counsel**  
Michael Hubner; **Vice President, Research, Testing & Insights** Liam McCormack;  
**Vice President, Business Strategy & Planning** Betsy Parker; **Vice President, Advocacy**  
Jessica Rich; **Vice President, Chief Marketing Officer** Kim Stehle; **Vice President,**  
**Development** Shar Taylor; **Vice President, Chief Financial Officer** Eric Wayne

## Keeping Leafy Greens Safe

### WHAT'S AT STAKE

This year's romaine lettuce E. coli outbreak, one of the worst foodborne illness outbreaks in recent history, is over. But it remains an unsolved mystery.

In late June, the Centers for Disease Control and Prevention reported that 210 people across 36 states were made ill by eating romaine. Almost half were sick enough to be hospitalized, and five of them died.

Investigators recently announced they'd found E. coli in canal water near where most of the season's romaine was grown. But more than three months after the outbreak began, they still didn't know exactly how the bacteria got into the lettuce. That, experts say, makes preventing future outbreaks much more difficult.

### HOW CR HAS YOUR BACK

Consumer Reports, with other consumer and food-safety groups, is calling on the Food and Drug Administration to propose requirements for comprehensive and rapid traceability of produce. We sent a letter to the agency urging it to implement long-overdue provisions of the 2011 FDA Food Safety Modernization Act that require the agency to establish record-keeping requirements for high-risk foods, to improve its ability to quickly trace the source of foodborne illness and initiate swift recalls.

"In an age where digital technology is instantly tracking everything from credit card purchases to lost dogs, the FDA still lacks a means to quickly determine where lettuce was grown or packaged," says Jean Halloran, director of food policy initiatives at Consumers Union, the advocacy division of Consumer Reports.

### WHAT YOU CAN DO

Sign our petition telling the FDA to modernize its system for tracking contaminated produce, at [CR.org/romaine](http://CR.org/romaine).

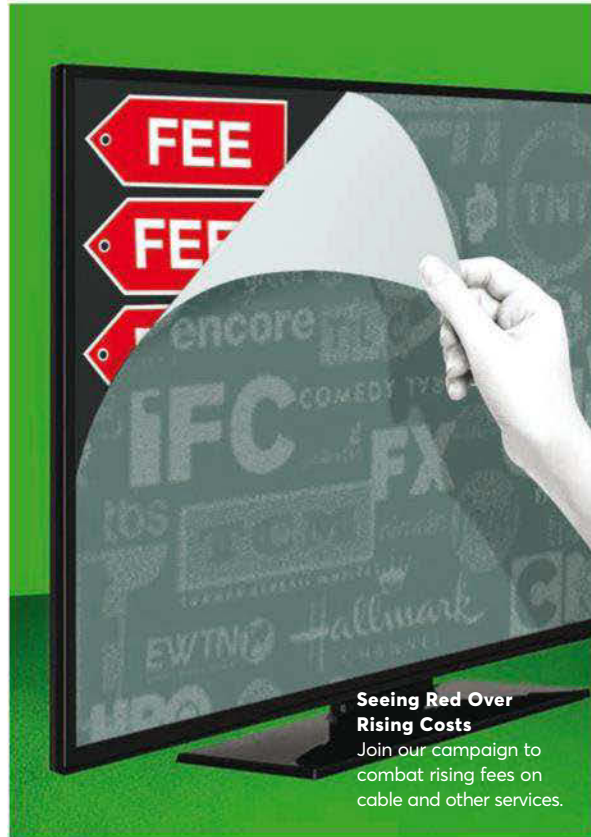

## Fighting Cable & Other Fees

### WHAT'S AT STAKE

We've heard you loud and clear: You're sick of fees. They drive up your cable and utility bills, inflate the cost of airplane and concert tickets, and chip away at the money you put in the bank. And they're often hidden until late in the shopping process, making it extremely difficult for consumers to comparison shop for a good deal.

That's why CR has launched a new national campaign, dubbed "What the Fee?!" By spotlighting some of the most outrageous examples of these fees, we hope to pressure companies into cleaning up their acts, and to give consumers the tools they need to push back.

Not surprisingly, we've found that consumers are particularly fed up with

the fees imposed by cable- and satellite-TV providers, who have a long history of hitting their customers with "broadcast TV fees," "regional sports fees," and the like—even though broadcast stations and sports seem like essential pieces of the service. To make matters worse, the size of such fees is rising, in some cases by 50 percent per year.

### HOW CR HAS YOUR BACK

More than 131,000 consumers have already signed our petition to the pay-TV industry, calling for an end to these ever-increasing fees, and demanding fair and transparent pricing practices. And this June, local consumers joined us as we delivered these signatures to executives at the Philadelphia headquarters of Comcast, the nation's biggest cable company.

### WHAT YOU CAN DO

Join our campaign and partner with us at [WhatTheFee.com](http://WhatTheFee.com), where you can tell us about the most outrageous fees you've

been forced to pay, sign our latest petition, and learn how to avoid some of these charges.

## Making Credit Freezes Free

### WHAT'S AT STAKE

Good news for consumers whose personal information was compromised in recent data security breaches, including the massive Equifax incident: A new law will require the big three credit-reporting companies to let consumers freeze and unfreeze their credit files free of charge.

Once you place a credit freeze, the bureau cannot release your information to potential creditors, which effectively locks down your credit. The provision, which passed as part of a larger financial regulatory bill, will go into effect in late September.

The new law could save consumers a bundle. In most states, consumers currently have to pay to put a freeze on their credit report at all three major credit bureaus, and pay a fee each time they lift it when applying for credit or, in certain cases, insurance.

### HOW CR HAS YOUR BACK

Consumer Reports has long worked to guarantee state-level protections on credit freezes and helped strengthen the new federal provision. We have also repeatedly called on Congress to pass stronger legislation requiring companies to adopt reasonable practices to ensure the safety of consumer data, with free credit freezes among our top demands. And we've called on Equifax executives to take specific steps to make customers affected by their breach whole, including paying for credit freezes, processing disputes promptly, and setting aside funds for compensation.

### WHAT YOU CAN DO

Sign our petition, at [CR.org/datasecurity0918](http://CR.org/datasecurity0918), telling Congress to pass stronger data security standards.



Our July 2018 cover story, “Road Trip!” offered ratings and strategies for a satisfying and safe summer adventure. Many of you wrote in to share more on-the-go tips. To add yours, go to [CR.org/roadtrip0918](https://www.consumerreports.org/roadtrip0918).

THREE ADDITIONS to your car emergency kit should be: 1) container of waterless soap, such as Gojo or Fast Orange; 2) roll of paper towels; and 3) plastic garbage bag. These will allow you to tidy up after using the tools in your kit no matter where you are.  
—Jim Schimpf, Derry, PA

I WAS GLAD to see that your article included info about taking pets along, but it missed the most basic and critical tip of all: Your pet (dog or cat) must be wearing a collar with an up-to-date ID tag at all times in case your pet gets lost. Make sure the ID tag has

at least one phone number that will be answered (like your cell) while you’re away from home. Also have a current photo of your pet and a copy of your pet’s medical records on your phone.  
—Kathy Bauch, Leland, NC

YOU SUGGEST THAT PEOPLE turn off the water to their house when they go on vacation. If your home has fire sprinklers, you just turned off your fire protection. In addition, what about your automatic lawn sprinklers?  
—Phil Davidson, Coppell, TX

**EDITOR’S NOTE** *If you have indoor fire sprinklers or an automatic lawn sprinkler system, you may want water running to the system while you’re away.*

IN YOUR LIST of the “Best Road-Trip Vehicles,” you didn’t include a category of sports/high-performance cars. Not

everybody is loading up a minivan with three kids and headed to Yellowstone. A weekend roadie to Vegas in a Challenger Hellcat might be just the ticket.  
—David Jackel, Hayward, CA

### Grill Skills

I LOVE GRILLING, and I enjoyed reading Paul Hope’s article, “Grow Your Grill Skills!” (July 2018). I found some very good advice there; however, I was disappointed in the sidebar “Face-Off: Charcoal.” I’m the owner of both a Big Green Egg and a Weber kettle grill, and the test was definitely apples and oranges. The main reasons are: Briquettes create too much ash to use in the Big Green Egg. It would be similar to cooking your food in a used ashtray. Price per pound may be right, but when I cook on my Green Egg, I can close it down and the remaining charcoal is

reusable the next time I cook. You can’t do that with the ashes that briquettes leave behind. I use briquettes on my kettle grill and lump charcoal on my Green Egg. I use briquettes over lump charcoal at a ratio of about 4 pounds to 1. That puts my cost of using lump charcoal at about half of what I spend on briquettes.

—Bruce Allen, Albuquerque, NM

I USED TO USE a grill brush very similar to the Nexgrill brush endorsed in “Gear for Great Grilling.” One evening last fall after eating grilled cod, I felt what seemed like a fish bone stuck between my teeth. I removed it using a tweezers and, to my surprise, found that it was a steel bristle from the brush. I was lucky to capture it; the bristle could have been very dangerous if swallowed. Such brushes should be banned.

—Jack Schmotzer, Alliance, OH

I HAVE LONG BEEN a member, and appreciate your thoroughness. I was astonished that “Gear for Great Grilling” recommended a metal-bristled grill brush. This recommendation runs counter to information in “Guard Against Wire Grill Brush Dangers,” an article on ConsumerReports.org, which says sharp bristles can get left behind after cleaning and stick to your food, posing a risk.  
—Chris Andrus, Liverpool, NY

**EDITOR’S NOTE** *We appreciate your concern. In the past, CR has warned of the potential dangers posed by grill-cleaning brushes with wire bristles. But we also know that they remain a widely used choice—more than 60 percent of CR members who took an online questionnaire told us they used a wire brush to clean their grill. In our recent evaluation of 10 cleaning tools, seven had wire bristles, and we did not observe any broken or loose bristles during our testing. If you see signs of bristle damage, replace the brush immediately. (The Nexgrill brush has a*

 Go to [CR.org/lettertoeditor](https://www.consumerreports.org/lettertoeditor) to share your comments for publication.



replaceable head, so you can keep a spare.) To minimize risk, you should always use a hard metal scraper to clear away most burned-on debris from the grates first, then allow the heat of the grill to turn food residue to ash. Use the wire bristle brush last, to get rid of ash or residue with light strokes because pressing down can bend or break the bristles. Last, inspect grill grates and the brush for any stray wire bristles before cooking food.

## Be Kind to Animals

LOVED THE ARTICLE “Shop Smarter for Sunscreen” (July 2018), but please offer more cruelty-free (no animal testing) options when reviewing personal-care products. There are good cruelty-free choices, and they do not receive proper attention.

—Sandra Smith, Santa Fe, NM

## Think Pink

RE: “TACKLING THE PINK TAX” (Building a Better World, Together, July 2018).

CONNECT WITH US



### FACEBOOK

fb.com/consumerreports  
fb.com/SomosCR



### YOUTUBE

/consumerreports



### INSTAGRAM

@consumerreports



### TWITTER

@consumerreports  
@SomosCR



### PINTEREST

/consumerreports



### LINKEDIN

/company/  
consumer-reports

Companies should be able to charge whatever they want, as long as there are competitive options. If the product or service is really exactly the same, women have an option: Buy the blue razor, buy the black comb. Or if I am willing to pay the extra price knowing it is the exact same product, it is a choice. Government should not interfere. That is why CR exists. Publish those comparisons, call out those companies, educate the consumer, and let us rule.

—Fausto Zamorano,  
Alpharetta, GA

THANK YOU for calling attention to the “pink tax.” This is an infuriating issue! I take exception to the last sentence in the article: “And when you’re in the store, consider buying a ‘male’ option that costs less.” This advice is problematic in two ways. First, it suggests consumers are the problem, not the businesses that choose to deceive consumers into thinking there is a real need for gendered products. Second, it ignores that when it comes to services, women have no choice but to pay the pink tax. When I show up as a woman, I don’t have the option of a man’s haircut or the men’s price for dry cleaning. Aside from these problems, thank you for your advocacy on behalf of women consumers.

—Maria Bevacqua, Mankato, MN

THE ARTICLE EMBRACES a cause that to me seems misdirected. The fact that items sold to women often cost more than identical items sold to men is not a tax. Call it a surcharge or some other name, but it is not a charge levied by a governmental body.

—William Menzel, Wisconsin Rapids, WI

IN YOUR UPDATE on the strategy of companies charging different prices for similar products targeting men vs. women, you advocate support of congressional intervention.

## JOIN THE CONSUMER REPORTS BOARD

Consumer Reports is seeking dynamic, dedicated candidates with a desire to advance our mission and improve the lives of consumers by serving on our Board of Directors. Ideal candidates will bring creativity, diversity of background and thought, experience in leadership, and a passion for empowering consumers and working to create a fairer, safer, and healthier marketplace. Applications should be submitted online at [CR.org/boardapplication](https://www.consumerreports.org/boardapplication) by Sept. 15, 2018. A committee of the Board will review applications, conduct interviews, and recommend a slate to stand for election to a three-year term of service beginning in October 2019. Board members are required to attend three meetings per year and participate in Board business by phone and email on an ongoing basis. No compensation is provided, but travel expenses are covered.

Please don’t encourage government involvement in situations where the consumer can easily be in the driver’s seat. Do what you can to educate, then let the buyer decide whether it’s worth spending more for the pink version of a product.

—Keith Crowell, Portage, MI

## Rental-Car Reservations

THE JULY ISSUE asks whether the deals on used cars from rental-car companies are as good as they seem (Ask Our Experts). It suggests that rental cars have a harsher life than other used cars. What the article ignores is that rental cars make up a sizable portion of cars sold at auctions and that many of these are purchased by used-car dealers. You need to check Carfax to see whether the car was initially purchased by a rental-car company if you want to avoid a rental car.

—Gary Oderda, Salt Lake City, UT

## Heart to Heart

I READ WITH INTEREST your July 2018 article “Heart Surgery Safety Guide.” As is well-known in the Ohio area, the Cleveland Clinic advertises itself as the No. 1 heart hospital in the country. I was rather confused

not to find the Cleveland Clinic among the Midwest hospitals listed in your ratings or among those that do not share data.

Can you explain the omission?

—Alfred Navarro, New Albany, OH

**EDITOR’S NOTE** *The Cleveland Clinic’s main facility, in downtown Cleveland, does earn a top score in heart bypass surgery. But it did not make our list of top heart hospitals because it does not report data for aortic valve replacement. Note that Fairview Hospital in Cleveland is also run by the Cleveland Clinic, and it does appear in our ratings, earning a top score in artery bypass surgery and an average score in valve replacement.*

## Nostalgic Note

IN “WHAT MEMORIES Are Made Of” (July 2018), no mention is made of one of the best ways to guard against the loss of digital images or the obsolescence of digital file formats: Print your pictures!



—Henry Richard Koelling,  
Hillsboro, OR

**CORRECTION:** In “Chill Out on These Mattresses” (August 2018, page 15), we published an incorrect Sleep Number mattress model in the list of the “warmest” mattresses. The correct model is the Sleep Number i8 bed.

# What We're Testing in Our Labs ...

In our 63 labs, we continually review and rate products. Here, timely picks for this month.

## Upright Vacuums

<p><b>WE TESTED:</b> 77 models  <b>WE TEST FOR:</b> How much embedded talc and sand an upright model can lift from a medium-pile carpet, how much sand it can pick up from bare floors, and more.</p> <p><b>ABOUT THE SCORES:</b>          Median: 58          Range: 33-74</p>	<p><b>Best Overall</b>          Kenmore Elite Pet Friendly 31150 (bagged)          \$350</p> <p><b>74</b>          OVERALL SCORE</p> 	<p><b>Boffo for Bare Floors</b>          Dyson Ball Multi Floor 2 (bagless)          \$400</p> <p><b>71</b>          OVERALL SCORE</p> 	<p><b>Budget-Friendly</b>          Hoover WindTunnel Max UH30600 (bagged)          \$180</p> <p><b>70</b>          OVERALL SCORE</p> 
---	---	--	---

## Canister Vacuums (Bagged)

<p><b>WE TESTED:</b> 8 models  <b>WE TEST FOR:</b> How much embedded talc and sand a canister model can lift from a medium-pile carpet, the strength of airflow through the hose, handling, and more.</p> <p><b>ABOUT THE SCORES:</b>          Median: 67          Range: 51-75</p>	<p><b>Best Overall and Reliable*</b>          Miele Complete C3 Marin          \$1,100</p> <p><b>75</b>          OVERALL SCORE</p> 	<p><b>Super Suction for Less</b>          Kenmore Elite Pet Friendly CrossOver 21814          \$500</p> <p><b>74</b>          OVERALL SCORE</p> 	<p><b>Nice Price</b>          Kenmore 81614          \$300</p> <p><b>71</b>          OVERALL SCORE</p> 
---	--	--	--

Ask Our Experts

**Which is better—a bagged or bagless vacuum?**



BAGLESS MODELS CAN SAVE you money because you don't have to buy replacement bags. But like bagged models, they have filters that need periodic cleaning or—for HEPA filters—replacing, probably more often than with bagged models. (Brands differ, but HEPA filters from Shark, for example, cost from \$3 to \$36 and last six months.) “Emptying a bagless vacuum can be messy, releasing some of the particles you just sucked up back into the air,” says Susan Booth, CR’s lead vacuum tester. That can be a problem for those sensitive to dust and allergens. Bagged models in our tests tend to be better at deep cleaning—an advantage in homes with carpeting or rugs.

ILLUSTRATION: SERGE BLOCH

For the latest ratings of these and other product categories, readers with a Digital or All-Access membership can go to [CR.org](http://CR.org).

## Sound Bars

**WE TESTED:** 28 models  
**WE TEST FOR:** Sound quality (tonal accuracy and reproduction of fine sonic detail), ease of use, and more.

**ABOUT THE SCORES:**

**Full-Featured**  
 Median: 70 Range: 54-74  
**Basic**  
 Median: 55 Range: 20-66

**Super Sound**  
 Samsung HW-K950 (full-featured)  
 \$1,400



**74**  
 OVERALL SCORE

**Easy to Use for Less**  
 Sonos Playbase (full-featured)  
 \$700



**72**  
 OVERALL SCORE

**Budget-Friendly Basic**  
 Yamaha YAS-207BL  
 \$300



**65**  
 OVERALL SCORE

## Pressure Washers

**WE TESTED:** 30 models  
**WE TEST FOR:** Versatility and efficiency in cleaning a range of surfaces, power, pressure, and more.

**ABOUT THE SCORES:**

**Gas**  
 Median: 73 Range: 60-78  
**Electric**  
 Median: 55 Range: 43-63

**Best Power and Pressure**  
 DeWalt DXPW3425 (gas)  
 \$600



**78**  
 OVERALL SCORE

**Excellent Cleaner for Less**  
 Simpson MS60763-S (gas)  
 \$320



**74**  
 OVERALL SCORE

**Electric Leader**  
 Craftsman 99016  
 \$140



**63**  
 OVERALL SCORE

## Folding Treadmills

**WE TESTED:** 27 models  
**WE TEST FOR:** Ease of use, including controls and display; quality of construction, including the motor and running deck; safety features; and more.

**ABOUT THE SCORES:**

Median: 74  
 Range: 48-84

**Takes the Lead**  
 NordicTrack Commercial 2450  
 \$1,800



**84**  
 OVERALL SCORE

**Handles up to 400 Pounds**  
 Bowflex BXT216  
 \$1,800



**84**  
 OVERALL SCORE

**Counts Your Steps**  
 LifeSpan TR1200i  
 \$900



**73**  
 OVERALL SCORE

## Budget-Friendly TVs

**WE TESTED:** 225 models  
**WE TEST FOR:** HD and 4K picture quality, including resolution; versatility; and more.

**ABOUT THE SCORES:**

**60-inch and larger**  
 Median: 71 Range: 50-88  
**55- to 59-inch**  
 Median: 68 Range: 41-88  
**39- to 43-inch**  
 Median: 57 Range: 41-71

**Big Screen, Small Price Tag**  
 65" LG 65UK6500AUA  
 \$980



**71**  
 OVERALL SCORE

**Excellent HD and 4K Picture**  
 55" TCL 55R617  
 \$650



**69**  
 OVERALL SCORE

**Great for Streaming**  
 43" Samsung UN43NU7100  
 \$480



**61**  
 OVERALL SCORE

**Note:** We rate different products according to different testing protocols; as a result, Overall Scores of one product category are not comparable with another. \*Source: 2017 Product Reliability Survey.

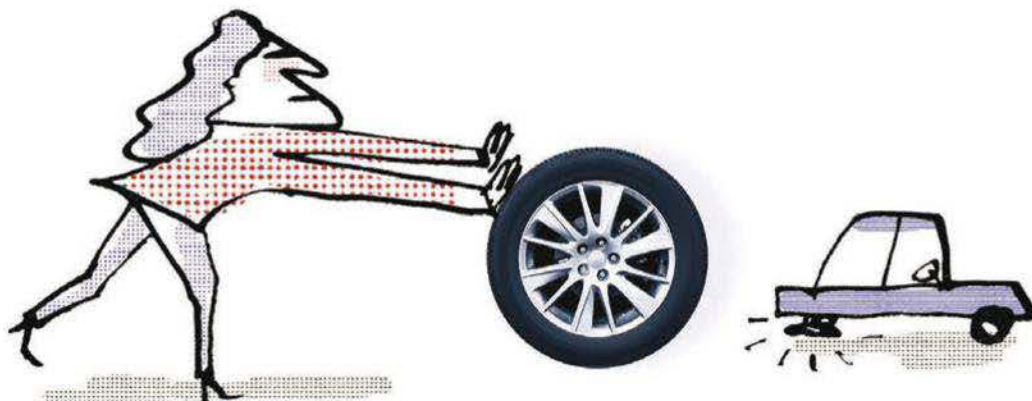

## I was stunned to discover that my new car doesn't have a spare tire. Was I ripped off?

Not really. About a third of new cars today do not come with a spare, though they may be equipped with a compressor and sealant kit to temporarily fix a flat tire. Some cars without spares come with “run-flat” tires, which are designed to operate for a limited distance after losing air from a typical puncture.

Carmakers are skipping the spare because of regulatory pressure to squeeze more miles out of every gallon of fuel: Ditching the 40 or 50 pounds that a tire and jack usually add to a car's weight helps to increase fuel economy slightly. (It also incidentally increases automakers' profits because they don't have to

pay for those parts.)

The problem is that a sealant kit won't help drivers if a tire's sidewall gets sliced or if the flat is caused by more extensive damage than a tread puncture. If you want to be prepared for any type of flat tire, some retailers and car dealers offer spare-tire kits, including a tire, jack, and lug wrench, starting at about \$150.

“Know how your car is equipped before you take delivery,” says Gene Petersen, CR's tire expert. “Don't assume the car you're about to buy has a spare tire. The best time to find out is in the showroom—so you can also use it as a negotiating point—not on the side of the road after you've had a flat.”

### I can't resolve a dispute with my neighbors over their barking dog. Should I hire a lawyer or a mediator?

When deciding whether to hire a lawyer or a mediator in a dispute, it's important to

understand the different roles they play, says Octavio Blanco, a CR money editor and New York State-certified mediator.

A lawyer works within the court system and represents his or her client's interests. (The other party also has a lawyer.) A neutral judge or jury decides how the dispute is resolved, unless the two sides come to an agreement before that. A mediator is also neutral and listens to both sides to help them reach an agreement.

Compared with a lawsuit, mediation is more collaborative from the beginning, is generally less expensive, and takes place outside the courts. A mediator does not issue a decision, as a judge or jury would, but takes each side's interests into consideration and encourages both to come to a compromise. Once there's an agreement, each side signs a contract. (Arbitration, which also takes place outside the courts, is different from mediation because the arbitrator issues a decision that is binding. CR opposes arbitration when it is forced on consumers in a contract for service, before a dispute arises, because it limits how

consumers can exercise their legal rights.)

“Bear in mind that mediation works only if both sides are open to compromise and willing to participate voluntarily,” Blanco says. If that's not the case, your best bet would probably be to hire a lawyer.

### Are there any real benefits to a curved TV?

Since TVs with curved screens hit the market more than five years ago, they've been promoted as offering a more “immersive” viewing experience than flat screens provide. But in our testing labs, we haven't found that to be true, even with larger 65-inch models.

“Compared to flat-screen TVs, there was no meaningful difference in picture performance in our tests,” says CR's head TV tester, Claudio Ciacci. “What's more, a curved screen introduces a subtle geometric distortion to the image when viewing from the sides or if the TV is placed too high up on the wall. So these TVs look best when viewed straight on, and at eye level.”

Curved-screen TVs can cost about \$100 more than a comparably sized flat model. If you do decide to buy one, you're likely to find a limited selection: Samsung is the only major manufacturer we're aware of that is still making curved-screen TVs.



LEARN

We have more than 140 in-house experts who research, test, and compare. Submit your questions at [CR.org/askourexperts](http://CR.org/askourexperts) ... and watch for the answers.

# CR Insights

***In the Know***

## Better Veggie Burgers



**TOP PICK**

✓ Amy's Light in Sodium California Veggie Burger \$6

**70** OVERALL SCORE

IT'S EASY TO assume that any frozen veggie burger is a healthy choice. But ingredient lists can vary widely, to the point that vegetables aren't even prominent. What's more, "even without meat, a veggie burger can still be high in calories and sodium," says Ellen Klosz, a CR nutritionist.

For a healthier patty, we advise that you scrutinize the nutrition details on the box. To help, we've served up four of our highest-rated products, plus some tips.

**1. Check the protein source.**

Though some veggie burgers contain grains and beans as their protein source, others are soy- or pea protein-based. Textured vegetable protein, soy protein concentrate, and soy protein isolates are highly processed ingredients and may not provide the same health benefits as whole soy foods, such as tofu.

**2. Scan for sodium.**

The burgers we tested had a range of sodium counts—

up to 500 mg per serving. Pick one that contains less than 15 percent—around 350 mg—of the daily limit of 2,300 mg, Klosz says.

**3. Find the fiber.**

A nutrient associated with heart-health, fiber can also help you feel fuller longer and maintain bowel health. The fiber count in the patties we tested ranged from 2 to 6 grams. If you choose a burger that's lower in fiber, try to balance it with a cup of sautéed

spinach and a hearty whole-wheat dinner roll, which can add another 6 grams of fiber.

**4. Do a quick calorie check.**

The veggie burgers in our tests had between 100 and 360 calories per patty—and that's before you add the bun (often about 120 calories) or any toppings. That said, some higher-calorie burgers are made with nutrient-dense ingredients, such as whole grains, beans, and seeds, so they may still be a good overall choice.

ILLUSTRATIONS: CHRIS PHILPOT

**VEGGIE GOOD**

👉 **Trader Joe's Quinoa Cowboy with Black Beans & Roasted Corn** \$3.70

**69** OVERALL SCORE



**GRILLED FLAVOR**

👉 **Boca All American Flame Grilled** \$3.50

**66** OVERALL SCORE



**VERY LOW SODIUM**

✓ **Engine 2 Tuscan Kale White Bean** \$5

**65** OVERALL SCORE



Face-Off

# Best Streaming Music Services

There are so many different music streaming services today—all with different pricing plans—that it can be hard to choose. To help, we've created this side-by-side comparison chart. All these services offer free trials so that you can kick the tires before handing over your money.

 Prime Music	 Apple Music	 Pandora	 Spotify	 YouTube Music
<p><b>COST</b></p> <p>Prime Music is included with Amazon Prime.</p> <p><b>MONTHLY:</b> \$8 to \$10 for Unlimited.</p> <p><b>FAMILY PLAN:</b> Available only to Prime members.</p>	<p>No free tier.</p> <p><b>MONTHLY:</b> \$10.</p> <p><b>FAMILY PLAN:</b> \$15 for up to six family members.</p>	<p>Streaming radio is free with ads.</p> <p><b>MONTHLY:</b> \$5 for ad-free; ad-free plus on-demand library is \$10 per month.</p> <p><b>FAMILY PLAN:</b> \$15 for on-demand for up to six family members.</p>	<p>Free with ads and limited on-demand song selection.</p> <p><b>MONTHLY:</b> \$10 for Premium.</p> <p><b>FAMILY PLAN:</b> \$15 for Premium for up to six household members.</p>	<p>Free with ads.</p> <p><b>MONTHLY:</b> \$10.</p> <p><b>FAMILY PLAN:</b> \$15 for Premium for up to six household members.</p>
<p><b>CR'S TAKE</b></p> <p>Amazon's dual offering can be a little confusing at first, but both are ad-free, on-demand services. Amazon Music Unlimited offers tens of millions of songs and thousands of playlists and stations; Prime Music has 2 million songs—a thinner selection than most services offer. Both work with Amazon's Alexa, and you'll get some extra content, such as commentary from select artists.</p>	<p>Apple Music has 45 million songs that can be accessed on macOS, Windows, iOS, and Android. Human editors create a variety of themed playlists. The service works seamlessly with HomePod, Apple's connected speaker. But the user interface can be a bit confusing.</p>	<p>Type in an artist or other keyword and Pandora creates personalized stations to fit your request. Apps are available for Android and iOS, and it works with smart speakers from Amazon, Google, and Sonos. But you can't upload your own music the way you can on Spotify or Apple Music.</p>	<p>Spotify combines 35 million-plus songs with playlists geared toward specific activities (workouts) and genres (jazz), as well as those created by friends. Spotify works with macOS and Windows, iOS and Android mobile apps, and many smart speakers.</p>	<p>Newer to the streaming scene, YouTube Music boasts easy search tools and suggestions based on taste and location, or time of day. The Premium tier is ad-free and offers the ability to download music and videos for listening when you don't have cellular or WiFi service.</p>
<p><b>WHO IT'S BEST FOR</b></p> <p><b>Amazon Prime members</b> may as well take advantage of the free service, especially if you have Alexa-enabled devices to play it on.</p>	<p><b>Consumers who already have large iTunes libraries</b> or who are otherwise committed to the Apple ecosystem.</p>	<p><b>Those who want a similar experience to a live radio station—</b> but one that uses an algorithm to fine-tune its offerings to your tastes the more you listen.</p>	<p><b>Listeners who enjoy building, browsing, and sharing playlists</b> with friends, and who want to easily connect a large music library to a variety of devices.</p>	<p><b>Heavy Google users,</b> particularly those who spend a lot of time listening to music or watching videos on YouTube.</p>

## WHAT 100 CALORIES LOOKS LIKE

### Cheese

Creamy, salty, soothing: What's not to love about cheese? But too much can, sadly, put a serious dent in your daily calorie, fat, and sodium allotments. Use our guide below, and go to [CR.org/cheese0918](http://CR.org/cheese0918) for more tips.



1½  
Babybel Original



1 oz.  
Kraft Pepper Jack



5½  
Lioni Ciliegine Cherry Size  
Fresh Mozzarella



2 oz.  
Low-Fat Cheddar Cheese



1 oz.  
Brie

PHOTOS: LEFT, JAMES WORRELL; FOOD STYLING: JAMIE KIMM

## CR Money-Saver PREMIUM GAS

If you're filling your tank with premium gas because that's what the car's manufacturer recommends—but does not *require*—you might be wasting money. We compared the fuel economy and acceleration of a 2015 Acura TLX four-cylinder and a 2016 Nissan Maxima V6 running on regular and premium fuel and found no difference in performance. "High-performance cars often require premium fuel to deliver the utmost in performance," says CR engineer Gene Petersen. "But, based on our testing, more mainstream vehicles won't exhibit any noticeable differences in fuel economy or performance." Fill up with premium fuel if your owner's manual says that it's required: You'll get superior performance and be protected by the powertrain warranty. But if premium is just recommended, CR's experts suggest you use regular to save.

### How to Clean Practically Anything™

# A Tidy, Shiny Laptop



✓ HP Spectre  
13-AE011DX  
\$1,150

81 OVERALL SCORE

#### CLEAN THE SCREEN

Turn off and unplug your computer, then use a lint-free cloth (the type that comes with eyeglasses) to clear surface dust. Soak a sponge in water and wring it out until it's just damp. (To combat fingerprints, you can use a 50:50 mix of water and isopropyl alcohol.) Move the

sponge in small circles, with light pressure. Never use ammonia-based products, ethyl alcohol, or other chemicals, warns CR's laptop tester, Antonette Asedillo. "They can damage an anti-glare coating and make a touch screen less responsive." And those screen

cleaners you see advertised? Save your money.

#### DE-GUNK YOUR KEYBOARD

An easy, cheap way to get all the dust and crumbs out of your keyboard is probably sitting on your desk: a sticky note. Turn off your laptop, then use the sticky end to

dab between the keys, working it like a lint roller to pick up tiny debris. Or turn your laptop upside down and give it a gentle shake. "You want to remove the mess, not push it deeper in," Asedillo says. To finish the job, wipe the keys with a cloth lightly moistened with plain water.

Food Sleuth

# A Tasty Cure for Sodium Overload

RESEARCH SHOWS PEOPLE consume about 50 percent more sodium every day, on average, than the maximum amount they should (2,300 mg). That's cause for concern, because surging sodium in your diet can contribute to high blood pressure and potentially harm your heart. The majority of sodium in our diets comes from packaged foods, but changing your seasoning habits while cooking or at the table can make a difference.

If everyone cut their sodium intake by just 400 mg per day—the amount in less than ¼ teaspoon of table salt—it could prevent an estimated 32,000 heart attacks and 20,000 strokes per year, according to one study. But skipping the salt shaker doesn't doom you to bland meals. By adding these alternative spices, you'll enjoy a tasty, healthier dish.

**Herbs (Fresh or Dried)**

Herbs supply vitamins and minerals, though they're not typically eaten in quantities that have much effect on your daily intake. One tablespoon of dried chervil, for example, has 26 milligrams of calcium and 90 milligrams of potassium. A quarter-cup of fresh parsley supplies a quarter of your daily need for vitamin C and 25 percent

for vitamin A. "Herbs boost the flavors on your plate, so you may not even miss the salt," says Ellen Klosz, a CR nutritionist.

**Hot Sauce**

A recent study found that spicy-food lovers ate an estimated half-teaspoon less salt per day than people who didn't like spicy foods, and they had lower blood pressure. "Hot sauces

provide a different taste profile to your food, and because many contain sodium, you don't have to add salt," Klosz says. But choose carefully. One teaspoon of Frank's RedHot Original Cayenne Pepper Sauce has 190 milligrams of sodium, for example. Stick to low- or no-sodium sauces, such as Trader Joe's Chili pepper sauce, which has 0 mg of sodium.

**Lemon and Lime**

Acidic flavors can also perk up a dish. "Lemon or lime juice brightens the flavor of food, so you perceive it as being tastier," Klosz explains. You can use these zesty citrus flavors while you're cooking and/or once your meal is cooked. Try a squeeze of either fruit over fish, chicken, whole grains, or vegetables.



**Shake It Off**  
Getting creative with seasonings means you can use less salt on your food.

PHOTOS, BOTTOM: CONSUMER REPORTS

CR Time Traveler **DISHWASHERS**



**1948** Before electric dishwashers, we test the Handi Mite—a faucet-hose with built-in detergent that squirts hot water on dishes—but discovered it often gave users an unwanted shower of scalding water.

**1952** The average American housewife "spends one and a half hours out of every 24 doing dishes," so we test electric dishwashers. A KitchenAid (below) is a top performer.



**1961** We test the Thermo-Pure Electric Dish Drier—a dish rack with a built-in hot air blast—and report that it may be very dangerous because it could give the user a lethal shock.

**1976** Our dishwasher testing tackles big, dirty loads: 10 place settings smeared with 18 kinds of food, including beef stew, spinach, tomato sauce, oatmeal, peanut butter, and more. Cups and saucers were soiled with coffee.





**SAFER**  
Use special characters and symbols.

**SAFER**  
Use a mix of numbers and uppercase and lowercase letters.

**PASSWORD**

Jump\$OverTh3Lazy

**LESS SAFE**  
Avoid common phrases, such as this one, taken from a famous pangram.

**SAFER**  
Longer passwords (12 characters or more) are safer than short ones.

Still Confused By ...

# What Makes a Strong Password

MOST PEOPLE KNOW they're supposed to create strong, unique passwords for all of their accounts, but not everyone does it.

Meanwhile, the high-profile hacks and thefts of consumer information continue to pile up, serving as powerful reminders of the importance of good password hygiene.

Here are some tips for setting good passwords and protecting them.

**Go long and complicated.**

Though "Password123" may be easy to remember, it's a disaster when it comes to security. Hackers usually try the obvious options first.

Ideally, a password should be composed of a long string of seemingly random uppercase and lowercase letters, numbers, and symbols, says Dan Nadir, vice president

of digital risk for the cybersecurity firm Proofpoint. "The easier it is for you, the easier it is for the bad guys," Nadir says.

**Don't recycle.**

Even a tech minimalist has countless passwords these days for everything from bank accounts to Pinterest. That's a lot to remember, but don't follow the temptation to use the same password for multiple accounts or to recycle an old favorite.

**Consider a password manager.**

If coming up with unique login credentials for every account is too hard, consider using a password manager, Nadir says. Services including LastPass, 1Password, and Dashlane can create long, effective passwords for each of your accounts, and enter them for you as needed. You'll need

to download software to your laptop and, if you choose, an app to your smartphone. Then swap out your old passwords as quickly or gradually as you like.

**Turn on two-factor authentication.**

Many sites allow you to turn on this setting, which requires users to enter a second form of identification, such as a code texted to a smartphone or a biometric identifier, such as a thumbprint.

That makes it a lot harder for hackers to access your account, even if they have the password. Yes, this will slow you down a bit, but it just may be enough to make hackers look for another target.

Though good passwords are important, turning on multifactor is a must, Nadir says. "Ultimately, that's going to be the thing that's going to save you."



**1983** Even though the push-button controls on the Maytag above (top) look impressive, we tell readers the model doesn't have more cycles than the plain-looking dial machine (bottom).

**1993** We note that utensil baskets are a useful addition to some machines.

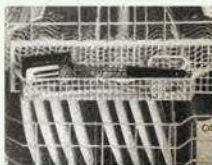

**1995** Consumers spend nearly \$600 million a year on detergents. About half that money goes to Cascade. But our tests reveal that a Palmolive powder outperforms 22 other detergents, including a Cascade powder and gel.

**2000** Based on a survey, we report Whirlpool to be the most reliable brand, but a popular Bosch model, below, is among the quietest.

**\$ Bosch Ascenta SHX3AR75 UC \$540**

**88** OVERALL SCORE



**2018** Today, a Bosch model tops our ratings—and is half the price of many other models we test.

Repair or Replace?

# Is a Busted Belt Curtains for Your Vacuum?

YOU'RE ZIPPING ALONG with your vacuum, when all of a sudden you feel the brush roller stop spinning and the vacuum's powerhead motor rev into high gear. It's still running, but it's not picking up much dirt. Is your vacuum dying? Not necessarily. It may just be a broken belt—the part of the machine that typically connects the brush roller to the motor shaft. “Fortunately, replacing the belt takes minutes and costs next to nothing,” says Susan Booth, who tests vacuums at Consumer Reports, and it can extend your appliance's life. Here's how to repair your vacuum in a few easy steps.

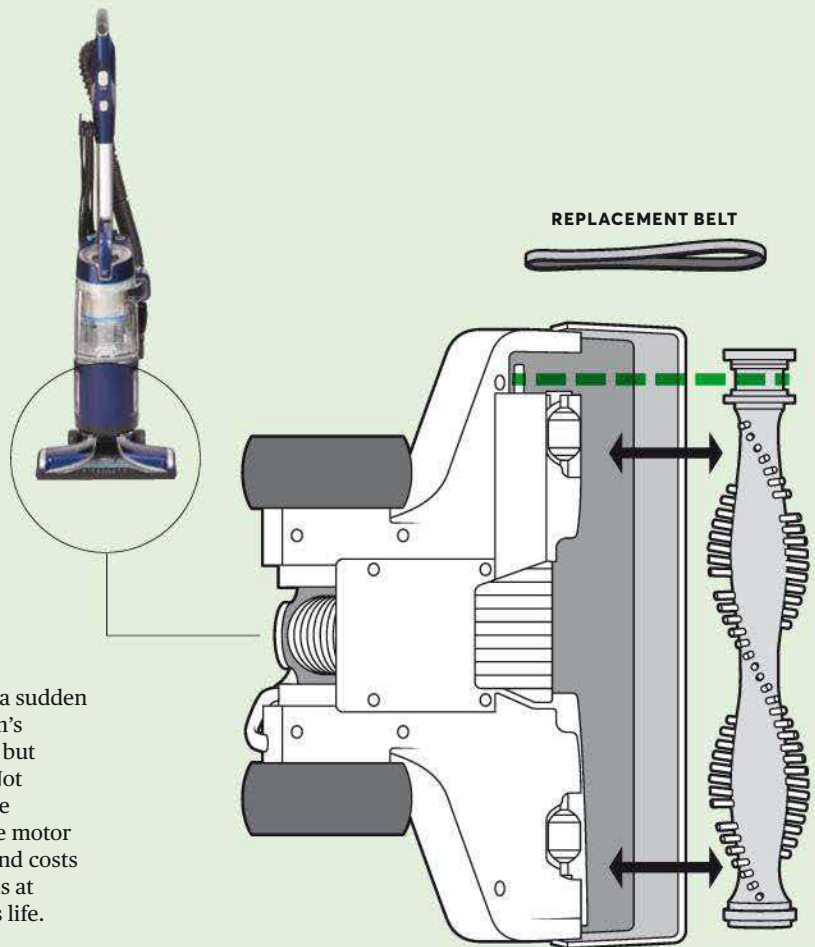

**STEP 1**

Buy a New Belt

Search for a replacement belt online using the vacuum model number or contact the manufacturer. Prices are usually in the \$5 range, and they're so cheap, you might as well buy two if you're already paying for shipping.

**STEP 2**

Open the Powerhead

Lay the unplugged machine on the floor with its underside facing up. Next, remove the bottom plate to expose the brush and belt. Some plates are held in place with screws, and others use some kind of quick-release latching mechanism.

**STEP 3**

Remove the Old Belt

Slide one end of the vacuum cleaner belt off the brush roller and the other end off the motor shaft. With the belt and brush removed, take a moment to clean around the motor bearings, which can become tangled with hair and fibers over time.

**STEP 4**

Hook on the New Belt

With the letters on the new belt facing out, hook one end onto the motor shaft and the other onto the brush roller. Then lock the brush back into its housing and refasten the bottom plate.

For a video of these steps, go to [CR.org/vacuumbelt0918](http://CR.org/vacuumbelt0918).

## September Is THE BEST TIME TO BUY ...

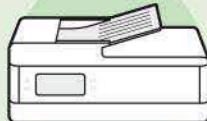

**Printers**

Back-to-school sales often include significant discounts on printers.

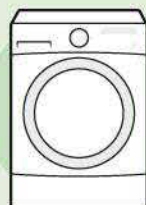

**Washing Machines**

Labor Day sales are a good time to upgrade your washer—and dryer, too!

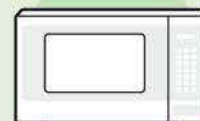

**Microwaves**

You're likely to see good deals this month on both countertop and over-the-range models.



## RECALLS



### LEXUS AUTOMOBILES

Toyota is recalling approximately 115,000 2006-2013 Lexus IS 350, 2010-2014 IS 350C, and 2007-2011 GS 350 and GS 450h vehicles. Material in the fuel pulsation dampers (part of the fuel-injection system) may harden and crack, causing gasoline to leak. Toyota explains that such a leak near an ignition source creates a fire risk. **What to do:** Lexus dealers will replace the fuel delivery pipe free of charge. Call Toyota at 800-331-4331 or Lexus at 800-255-3987, or go to [toyota.com/recall](http://toyota.com/recall) for more details. Also, to stay informed about recalls for your vehicles, readers with a Digital or All-Access membership can use our free Car Recall Tracker.

### KIDS' CRAFT KITS



Michaels is recalling about 263,000 Creatology pottery wheel kits and 110,000 Creatology spin art kits because the battery compartment in the kits can overheat and pose a hazard of fire and burns. The kits were sold at Michaels stores and on its website from August 2011 through February 2018 for about \$25. **What to do:** Take the kit away from children and return it to any Michaels store for a full refund. Call Michaels at 800-642-4235 or go to [michaels.com](http://michaels.com) for details.

### HONDA ROVS



American Honda is recalling about 65,000 model year 2016 through 2017, and some

model year 2018, Honda Pioneer 1000 recreational off-highway vehicles because the muffler can overheat, causing the plastic heat shield to melt or catch fire, posing fire and burn hazards. **What to do:** Stop using the ROV and contact an authorized Honda Powersports dealer to schedule an appointment for a free inspection and repair. American Honda has details at [powersports.honda.com](http://powersports.honda.com), or call 866-784-1870.



### LADDERS

Werner is recalling about 78,000 aluminum ladders because they can break during use and pose a fall hazard. The ladders were sold at Home Depot and Lowe's stores from April 2018 through May 2018 for \$180 to \$275. **What to do:** Stop using the ladder and return it to the store where you bought it to get a full refund. Call Werner at 888-523-3370 or go to [wernerco.com](http://wernerco.com) for more details.



### LED TUBE LAMPS

GE Lighting is recalling about 46,000 packages of LED tube lamps (two lamps per package) because pins on one end of the lamp can be energized during installation/removal, and pose an electric shock and electrocution hazard. The lamps were sold at Lowe's stores and its website from approximately November 2017 through April 2018 for about \$15. **What to do:** Call GE Lighting at 800-338-4999 or go to

[gelighting.com](http://gelighting.com) for instructions on removing the lamps and to get a \$17 gift card refund. Make sure the light switch is off before trying to change the tube.

### SNOW BLOWERS



Amerisun is recalling about 34,600 PowerSmart snow blowers because the pulley bolt can loosen and cause the blower to get stuck in drive mode, posing an injury hazard. The blowers were sold at Home Depot stores and online at [amazon.com](http://amazon.com) and other websites from July 2015 through February 2018 for \$500 to \$800. **What to do:** Don't use the snow blower. Inspect it to determine whether it has a loose pulley bolt. Inspection instructions can be found at [powersmartusa.com/pages/bolt-inspection-instruction-sheet](http://powersmartusa.com/pages/bolt-inspection-instruction-sheet). Consumers with a loose pulley bolt should contact Amerisun at 800-791-9458 or go to [powersmartusa.com](http://powersmartusa.com)

for a free repair kit or for instructions on how to get the bolt tightened free of charge.

### NERF GO-KARTS FOR KIDS



Hauck is recalling about 26,300 Nerf Battle Racer go-karts because the steering wheel can detach, break, or crack while being used, posing a laceration and/or collision hazard. The go-karts were sold at stores and online between January 2016 and March 2017 for \$200 to \$300. **What to do:** Stop using the go-kart and call Hauck at 877-428-2545 or go to [hauck-toys.com](http://hauck-toys.com) to get a new steering wheel.

### VIDEO MONITORS



Lorex is recalling about 22,000 video monitors because the batteries can overheat, swell, and expand, and cause the battery cover to open or come off, exposing hot batteries and posing a burn hazard. The monitors were sold in bundles at Best Buy stores and on various websites from April 2014 through March 2017 for \$150 to \$330. **What to do:** Stop using the monitor. Call Lorex at 844-265-7388 or go to [lorextechnology.com](http://lorextechnology.com) to get a full refund.

### DON'T BUY: SAFETY RISK

## Bell 4Forty Bike Helmet



CR has identified this bicycle helmet as a "Don't Buy: Safety Risk" after the chinstrap buckle broke in our routine testing. A buckle failure like this can allow the helmet to come off your head or get pushed out of position during an accident

so that it no longer offers adequate protection. Of the 23 helmets we evaluated this year, the Bell 4Forty was the only one that failed our test. We notified the Consumer Product Safety Commission, along with Bell Sports, which is looking into this matter.

# Product Update

The latest ratings from our labs

Appliances and devices that owners of portable generators say are critical to operate during a power outage.

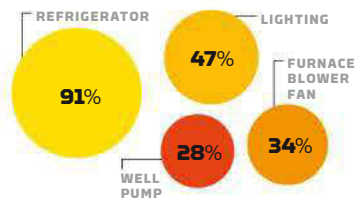

Source: Consumer Reports' 2016 Summer Generators Survey.

## More Power to You!

Learn how to choose—and safely use—a generator that will give you all the juice you need when the lights go out.

by Paul Hope



**\$** Generac  
GP5500 5939  
\$700

**67** OVERALL SCORE

**THE TYPICAL AMERICAN** household loses power once or twice a year, for an average of about 3 hours, according to the U.S. Energy Information Administration. But some power outages, such as those caused by extreme weather, can last for days. When they do, homeowners can face a long list of inconveniences and expenses, ranging from spoiled food and frozen pipes to flooded basements and moldy walls.

A generator is a first line of defense against all these problems. But with models ranging from small recreational units that cost a few hundred dollars and can power a single appliance to standby models that can cost \$5,000 and power a whole home, choosing a generator can be daunting. “Buy the smallest generator that will meet your power needs,” advises Consumer Reports test engineer Dave Trezza. “That will minimize the amount of fuel you need to keep on hand to run it.” (To determine which size you’ll need, see “Add Up Your Energy Needs,” on page 22.)

In the following pages, we offer guidance on how to choose the generator that’s right for you, provide expert advice on the safest way to operate it, and include ratings for dozens of models that were subjected to rigorous testing in CR’s labs.

To begin, choose the scenario below that is closest to your own to get an idea of the type of generator that could best meet your needs. Then turn to the chart on the following page for the pros and cons of each type.

**SCENARIO 1:** You experience frequent, sometimes prolonged, outages and/or

## GENERATOR SAFETY TIPS

Dozens of people die in the U.S. each year from carbon monoxide poisoning from a portable generator. Follow these tips to keep safe when you’re keeping the lights on:

1. Always operate a generator outdoors, at least 20 feet from your home and with the exhaust port pointed away from the house.
2. Never run a generator in an enclosed space, such as a garage, porch, or carport, even with the windows and doors open.
3. Have a licensed electrician install a transfer switch or an interlock device at your home’s circuit breaker panel to prevent the risk of electrocuting line workers when power is restored.
4. If you use an extension cord with your generator, choose one that’s rated for outdoor use and of a suitable gauge. (See your generator’s owner’s manual; we recommend a 12-gauge cord.) Never run the cord in a spot where it can be pinched or worn, such as under a rug.
5. Allow your generator to cool before adding gasoline to prevent it from igniting if it spills.
6. Make sure you have working carbon monoxide alarms outside every sleeping area and on every level of your home, including the basement. Replace any units that are more than 5 years old, and install fresh batteries and use the test function before firing up the generator.

live in an area prone to severe weather events, such as blizzards, ice storms, and hurricanes.

**GENERATORS TO CONSIDER:** Home standby, large inverter, and portable.

These have enough juice to power your whole house and can connect directly to your home’s circuit breaker panel to power appliances that are hardwired, such as central heat and air conditioning, well pumps, sump pumps, and electric ranges and water heaters. If you have any of these and need them to work in a power outage, be sure to have a transfer switch connected to your breaker box.

**SCENARIO 2:** You have occasional outages—sometimes sustained—but don’t want to spend thousands on a home standby generator.

**GENERATORS TO CONSIDER:** Large inverter and portable.

Unless you experience numerous power outages a year, you might not be willing to spend \$10,000 or more to buy a stationary unit and have it installed. You can save thousands of dollars if you don’t mind having to pull your inverter or portable generator out of a garage or shed and hook it up during the occasional outage.

**SCENARIO 3:** You rarely lose power, but you want a generator for some peace of mind.

**GENERATORS TO CONSIDER:** Midsized inverter and recreational.

Midsized inverters have ample power to run a fridge and a window A/C or space heater. Recreational models are compact enough to toss into the back of a pickup to power a TV and cooktop at a tailgate.



INSIDE  
CR'S LABS

To evaluate generators in CR’s labs, our testers hook them up to air conditioners, space heaters, a well pump, and lights, then measure their output and the quality of the power they deliver. “For standby generators we use a couple of 18,000-Btu/hr. air conditioners and add some 220-volt heaters,” says CR test engineer Dave Trezza. “All of those appliances and equipment simulate the load a whole-house generator would need to power.”



CR test engineer  
Dave Trezza

# Add Up Your Energy Needs

Use this chart for an idea of how much of your home a generator will power in an outage and to determine the type and size of unit you need.

ABLE TO POWER



## Recreational Inverter

POWER OUTPUT UP TO 2,000 WATTS      PRICE RANGE \$400-\$1,000

✓ **YAMAHA EF2000isV2**  
\$900



73

**CR'S TAKE:** This neat little generator runs for 5 to 11 hours on a modest 1.1 gallons of fuel, puts out 1,600 watts, has two outlets plus a 12-volt port, and can be paired for extra juice.

### PROS

The lightest type of generator. (Most models weigh around 60 pounds.)  
Extremely quiet.  
No installation costs.  
Easy to store and transport.  
You can pair most units to increase output.  
Many come with user-friendly features such as fuel-level indicators and smartphone apps.

### CONS

Enough to power a fridge, some lights, and a phone charger but not much else.  
Can't be connected to a circuit breaker panel or used to power any device without a standard plug.  
The most expensive models cost as much as a portable generator, which can do far more.

## Midsized Inverter

POWER OUTPUT UP TO 3,500 WATTS      PRICE RANGE \$1,000-\$1,700

✓ **HONDA EG2800i**  
\$1,000



79

**CR'S TAKE:** This neatly packaged generator delivers 2,500 watts quietly and efficiently. It earned top marks for delivering steady, reliable power.

### PROS

Lightweight: Most models weigh less than 150 pounds.  
Quiet.  
Efficient—capable of keeping the fridge running and the lights on for 8 to 18 hours using only 2 to 3 gallons of gas.

### CONS

They can generally power only 110-volt items with a standard two- or three-prong plug, ruling out well pumps and heating and cooling equipment. You can now find special 110-volt transfer-switch kits, but the installation costs make them an impractical choice because you could opt for a portable generator with a 220-volt transfer switch for the same cost.

ALL THESE ...

+ 10,000 BTU/HR. WINDOW AIR CONDITIONER

- Refrigerator 700 W
- TV 200 W
- Laptop 200 W
- 5-10 lights 250 W
- Smartphone charger 20 W
- Home security system 100 W

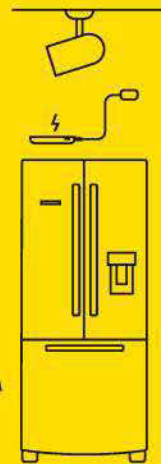
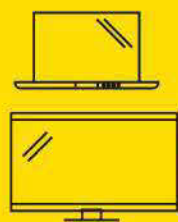

- OR ONE OF THESE:
- Toaster oven 1,200 W
- Hair dryer 1,200 W
- Washing machine 1,200 W
- Space heater 1,500 W
- Coffee maker 1,000 W

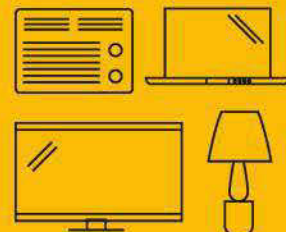

## Portable

POWER OUTPUT  
UP TO 7,500 WATTS

PRICE RANGE  
\$700-\$2,800<sup>†</sup>

**\$** GENERAC  
RS7000E  
\$1,000



72

**CR'S TAKE:** The top portable generator in our ratings produces 7,000 watts and deftly handles surges in demand without overloading. It has electric start and low-oil shutoff.

### PROS

The best value in terms of cost vs. capacity.

Certain models produce enough energy to meet all the power demands in your home.

Can be connected to your breaker panel with a transfer switch to run hardwired equipment, such as a well pump.

### CONS

Costs as much to connect to your home's circuit breaker panel as the generator itself.

They're noisier than large inverter and home standby generators.

They usually run only on gasoline and use a lot of it, compared with inverters.

Bulky: Most weigh close to 300 pounds.

Should not be used in rain or snow without protection, such as an open-sided tent.

## Large Inverter

POWER OUTPUT  
UP TO 7,500 WATTS

PRICE RANGE  
\$1,400-\$4,000<sup>†</sup>

**✓** HONDA  
EU7000iS  
\$4,000



79

**CR'S TAKE:** Quiet, efficient, capable, and easy to move and use. It has electric start and low-oil shutoff, which stops the engine to avoid damage if the oil level drops too low.

### PROS

Most produce enough energy to run your refrigerator, lights, and another essential, such as a furnace or small central air-conditioning unit.

Can be connected to your breaker panel to run hardwired equipment, such as a well pump. Quiet.

Produces steady power ideal for sensitive electronics, such as stereo equipment.

Fuel-efficient.

### CONS

Expensive. Only models costing \$3,000 to \$4,000 perform well enough in our tests to warrant serious consideration.

They can't run on natural gas or propane, so you still need to keep stabilized gasoline on hand.

## Home Standby

POWER OUTPUT  
UP TO 20,000 WATTS

PRICE RANGE  
\$2,000-\$6,000<sup>†</sup>

**✓** CHAMPION  
100179  
\$2,800



93

**CR'S TAKE:** This top-of-the-line standby generator is whisper quiet and effortlessly aced tests for delivering steady, reliable current. It can power an entire house with ease.

### PROS

Permanently installed (usually next to the house), they kick on automatically during an outage to provide uninterrupted current.

They can power everything in a typical home simultaneously, up to their maximum output.

They can be set up to run indefinitely on natural gas or can be fueled by propane.

No need to connect cables, flip a switch, or start the engine.

### CONS

With few exceptions, they're more expensive than other types of generators.

Installation costs can run into the thousands.

They cannot be installed in low-lying areas prone to flooding and can't be moved in the event of a flood.

## + WELL PUMP, SUMP PUMP, AND GAS OR PROPANE FURNACE

OR ONE OF THESE:

8-inch burner on an electric range  
2,000 W

Dishwasher 1,500 W



ILLUSTRATIONS BY THE TOM AGENCY

## > EVERYTHING UNDER THE ROOF

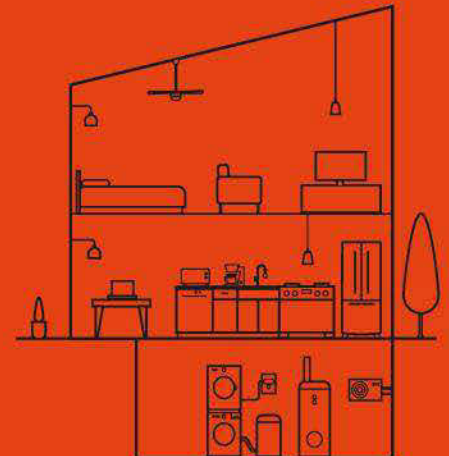

<sup>†</sup> Plus \$500 to \$1,500 to connect to a circuit breaker panel.

<sup>‡</sup> Plus \$2,500 to \$15,000 for installation.

**Ratings** > **Current Events** Let size and circumstance guide your generator purchase.

	Recommended	Rank	Brand & Model	Overall Score	Price	Test Results				Features						
						Power delivery	Power quality	Noise	Ease of use	Run-time range (hr.)	Claimed output (watts) <sup>1</sup>	Weight (lb.)	Fuel type <sup>2</sup>	Fuel shutoff	Low-oil shutoff	Electric start

**LARGE HOME STANDBY GENERATORS**

<p>The largest of any generator type, these permanently installed models produce up to 20,000 watts and run on propane or natural gas. They typically kick on automatically and are designed to power everything in your house simultaneously. They're also the most expensive option when you factor in installation.</p>	✓	1	<b>Generac 7031</b> <sup>2</sup>	<b>93</b>	\$3,100	↑	↑	↑	↑	163-342	NG 10,000 LPG 11,000	NA	NG/ LPG	•	•	•	
	✓	2	<b>Champion 100179</b> <sup>2</sup>	<b>93</b>	\$2,800	↑	↑	↓	↑	131-265	NG 11,000 LPG 12,500	NA	NG/ LPG	•	•	•	
	✓	3	<b>Kohler 14RESAL</b> <sup>2</sup>	<b>93</b>	\$3,700	↑	↑	↑	↑	134-230	NG 12,000 LPG 14,000	NA	NG/ LPG	•	•	•	
	✓	4	<b>Cummins RS13A</b> <sup>2</sup>	<b>91</b>	\$3,400	↑	↑	↓	↑	139-216	NG 13,000 LPG 13,000	NA	NG/ LPG	•	•	•	
	✓	5	<b>Briggs &amp; Stratton 040546</b> <sup>2</sup>	<b>90</b>	\$3,600	↑	↑	↓	↑	126-208	NG 10,800 LPG 12,000	NA	NG/ LPG	•	•	•	

**SMALL HOME STANDBY GENERATORS**

<p>Permanently installed, these run on natural gas or propane and typically kick on automatically during an outage, producing up to 10,000 watts.</p>	Ⓢ	1	<b>Champion 100174</b> <sup>2</sup>	<b>94</b>	\$2,000	↑	↑	↑	↑	228-353	NG 7,500 LPG 8,500	NA	NG/ LPG	•	•	•	
	✓	2	<b>Winco PSS8B</b> <sup>2</sup>	<b>92</b>	\$4,400	↑	↑	↓	↑	221-294	NG 7,600 LPG 8,400	NA	NG/ LPG	•	•	•	
		3	<b>Briggs &amp; Stratton 040445</b> <sup>2</sup>	<b>73</b>	\$2,000	↑	↓	↓	↑	226-366	NG 7,200 LPG 8,000	NA	NG/ LPG	•	•	•	

**PORTABLE GENERATORS**

<p>Weighing 200 to 300 pounds, these produce up to 7,500 watts and can power entire circuits when connected to a breaker box by a transfer switch. They cost far less than large inverter models but use more fuel and make far more noise.</p>	Ⓢ	1	<b>Generac RS7000E</b>	<b>72</b>	\$1,000	↑	↑	↓	↑	9-15	7,000	235	Gas	•	•	•	•
	Ⓢ	2	<b>Troy-Bilt XP7000 30477A</b>	<b>72</b>	\$900	↑	↓	↓	↑	12-18	7,000	270	Gas	•	•	•	•
	✓	3	<b>Honda EM6500SXK2</b>	<b>70</b>	\$2,800	↑	↑	↓	↑	8-13	5,500	273	Gas	•	•	•	•
	Ⓢ	4	<b>Briggs &amp; Stratton 30470</b>	<b>69</b>	\$900	↑	↑	↓	↑	8-12	7,000	270	Gas	•	•	•	•
	✓	5	<b>Briggs &amp; Stratton 30549</b>	<b>69</b>	\$1,030	↑	↑	↓	↑	9-15	7,500	280	Gas	•	•	•	•
	✓	6	<b>DeWalt DXGNR7000</b>	<b>69</b>	\$1,000	↑	↑	↓	↑	9-18	7,000	240	Gas	•	•	•	•
	Ⓢ	7	<b>Generac GP5500 5939</b>	<b>67</b>	\$700	↑	↑	↓	↑	8-14	5,500	212	Gas	•	•	•	•
	✓	8	<b>NorthStar 165603</b>	<b>66</b>	\$1,600	↑	↓	↓	↑	8-12	6,600	252	Gas	•	•	•	•
	✓	9	<b>Yamaha EF7200DE</b>	<b>65</b>	\$1,550	↑	↓	↓	↑	9-14	6,000	279	Gas	•	•	•	•
		10	<b>Briggs &amp; Stratton 30592</b>	<b>62</b>	\$800	↑	↑	↓	↑	8-14	6,250	239	Gas	•	•	•	•
		11	<b>Ridgid RD905712</b>	<b>59</b>	\$700	↓	↑	↓	↑	8-13	5,700	218	Gas	•	•	•	•
		12	<b>Generac RS5500</b>	<b>58</b>	\$700	↓	↑	↓	↑	7-12	5,500	208	Gas	•	•	•	•
		13	<b>DEK Pro DEK6500</b>	<b>53</b>	\$700	↓	↓	↓	↓	7-12	6,500	219	Gas	•	•	•	•

**HOW WE TEST:** Overall Score reflects a generator's ability to deliver steady, reliable power without producing excessive noise, as well as the convenience of its features. We connect window air conditioners, lights, and space heaters to the

generators we test. We also connect and turn on a well pump (for smaller models we use a window air conditioner) to simulate a surge in demand for current. How well a generator handles this spike (without tripping its circuit breaker or reducing

the voltage it delivers) determines its score for **Power delivery**. The consistency of voltage during the test is reflected by **Power quality**. **Noise** is an assessment of sound intensity, measured in decibels, at 23 and 50 feet (distances that replicate how

far a generator might be placed from your house and a neighbor's house, respectively). **Ease of use** reflects the maneuverability of generators that aren't permanently installed, as well as helpful features such as electric start and low-fuel shutoff.



	Recommended	Rank	Brand & Model	Overall Score	Price	Test Results				Features						
						Power delivery	Power quality	Noise	Ease of use	Run-time range (hr.)	Claimed output (watts) <sup>1</sup>	Weight (lb.)	Fuel type <sup>2</sup>	Fuel shutoff	Low-oil shutoff	Electric start

#### LARGE INVERTER GENERATORS (220 VOLTS)

Quiet, fuel-efficient, and pricey, these generators can power much of your house. They weigh 200 pounds or more and produce up to 7,500 watts.	✓	1	<b>Honda EU7000iS</b>	79	\$4,000	↑	↑	↑	↑	8-16	5,500	292	Gas	•	•	•
		2	<b>Yamaha EF6300iSDE</b>	61	\$3,400	↓	↑	↑	↑	6-13	5,500	246	Gas	•	•	•
		3	<b>Briggs &amp; Stratton Q6500</b>	39	\$1,400	↓	↑	↓	↑	7-16	5,000	156	Gas	•	•	•

#### MIDSIZED INVERTER GENERATOR (110 VOLTS)

Weighing up to 150 pounds, these produce up to 3,500 watts and work only with extension cords or a special 110-volt transfer switch.	✓	1	<b>Honda EG2800i</b>	79	\$1,000	↑	↑	↑	↑	7-17	2,500	81	Gas	•	•	•
--	---	---	----------------------	----	---------	---	---	---	---	------	-------	----	-----	---	---	---

#### RECREATIONAL INVERTER GENERATORS (LESS THAN 2,000 WATTS)

These ultraportable models weigh about 60 pounds and produce up to 2,000 watts. They can be used to power only 110-volt items with a standard two- or three-prong, properly rated extension cord.	✓	1	<b>Honda EU2000iT1A1</b>	77	\$1,000	↑	↑	↑	↑	4-8	1,600	53	Gas	•	•	•
	✓	2	<b>Yamaha EF2000isV2</b>	73	\$900	↑	↑	↑	↑	5-11	1,600	53	Gas	•	•	•
	✓	3	<b>Predator 62523</b>	72	\$500	↑	↑	↑	↑	4-10	1,600	56	Gas	•	•	•
	✓	4	<b>Honeywell 6066</b>	72	\$600	↑	↑	↑	↑	3-8	2,000	59	Gas	•	•	•
		5	<b>Briggs &amp; Stratton 030651</b>	71	\$650	↑	↑	↑	↑	4-9	1,700	60	Gas	•	•	•
		6	<b>Ryobi RYI2300BT</b>	70	\$600	↓	↑	↑	↑	6-14	1,800	59	Gas	•	•	•
		7	<b>Champion 73536i</b>	70	\$450	↑	↑	↑	↑	4-10	1,700	55	Gas	•	•	•
		8	<b>Generac iQ2000</b>	69	\$800	↓	↑	↑	↑	5-13	1,600	53	Gas	•	•	•



### Are the New High-Tech Generators Worth the High Cost?

Unlike conventional generators, which run at full power all the time, inverter generators increase or reduce engine RPMs depending on power demands, making them more fuel-efficient. They're also much quieter than conventional units. "You have to shout to be heard over a conventional

generator," says Dave Trezza, who oversees CR's generator testing. "But you can carry on a conversation next to an inverter generator." That quietness and efficiency comes at a premium. For instance, the Honda EU7000iS inverter generator costs \$4,000 and

has an output of 5,500 watts, while the Generac RS7000E—a conventional model—costs \$1,000 and delivers 7,000 watts. You'd never save enough fuel with the inverter generator to recoup that loss. CR's experts say there are only two reasons to consider an inverter:

portability (for recreational models) and noise. So if you want a light-duty generator that's easy to transport, or if you just want to get a good night's sleep without the loud drone of a traditional portable generator in the background, an inverter might be worth the investment.

# Eat Yo

FRUIT & VEGGIE  
SUPERPOWERS  
P. 31

HOW TO LOVE  
YOUR LEAFY  
GREENS  
P. 28

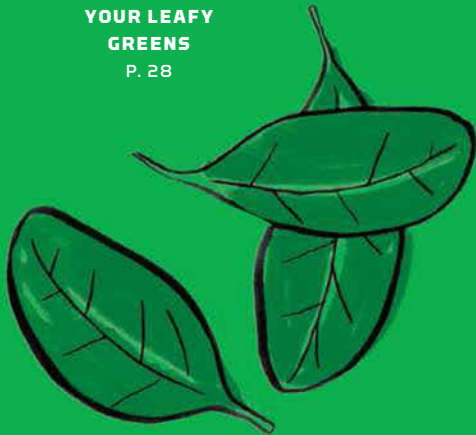

# Head

Is it safe to eat **LETTUCE** again? Are there ways  
seafood's **HEART-HEALTHY BENEFITS** without  
**DRINKS** a bust? We point you to the facts so  
advantage of the nutritional benefits of  
as well as discover tasty new ways to prep

STAYING HAPPY,  
HEALTHY & HYDRATED  
P. 34



# ourself

# lthy



SMART  
SHOPPING  
AT THE  
FARMERS  
MARKET  
P. 35

to buy **ORGANIC** for less? Can you enjoy  
ingesting too much mercury? Are **SPORTS**  
that you and your family can take full  
**FRUITS, VEGETABLES,** and **FISH,**  
and cook them.

WHY YOU SHOULD  
EAT MORE FISH  
P. 32

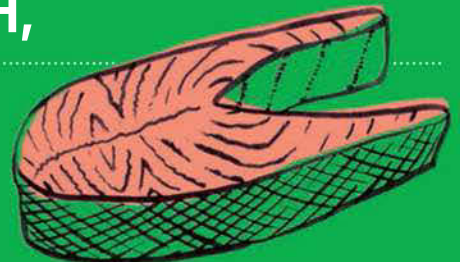



# How to Love Your Leafy Greens

Spinach, romaine lettuce, Swiss chard—these and other leafy greens are among **THE HEALTHIEST FOODS YOU CAN EAT**. “Few other foods pack as many nutrients for so few calories—fewer than 10 calories per cup, raw,” says Amy Keating, R.D., a CR nutritionist. In fact, in a study published in the journal *Preventing Chronic Disease*, which ranked 41 fruits and vegetables by their nutrient density, the top 10 were leafy greens.

Here, the key health benefits they provide and a few ideas for how to fit more of them into your daily diet.

## Potent Disease Fighters

Leafy greens contain important compounds necessary for overall health. “They tend to be very high in vitamin K and folate,” says Dana Hunnes, R.D., Ph.D., an adjunct assistant professor at the UCLA Fielding School of Public Health. Vitamin K helps blood to clot, and folate is a type of B vitamin important for cell division, which is key to our body’s ability to heal itself.

Scientists have linked leafy greens to a lower risk of many chronic diseases. Some of the latest research suggests that they may be beneficial for brain function. A January 2018 study from Rush University Medical School in Chicago found that eating as little as 1½ cups of lettuce daily—or just more than ½ cup of cooked greens—may delay the decline in memory and cognitive skills that can rise with age. Those who ate them enjoyed brain functionality that was as strong as that of people 11 years younger. While greens aren’t the only food that supports a healthy brain, “when it comes to slowing cognitive decline, [eating leafy vegetables] appears to be one of the most significant behaviors you can adopt,” says lead researcher Martha Clare Morris, Sc.D., a nutritional epidemiologist at Rush.

Many studies support the notion that eating leafy greens leads to a healthier heart. For example, a detailed analysis of 95 studies of the connection between

various fruits and vegetables and diseases, published in the *International Journal of Epidemiology*, found that leafy greens were linked to a lowered risk of death from heart disease.

Leafy greens are also packed with lutein and zeaxanthin, antioxidants that support healthy vision. These nutrients are found in the retina and lens of the eye, where they filter damaging blue light and ultraviolet rays from the sun, helping to prevent macular degeneration and possibly cataracts.

Certain leafy greens—such as arugula, bok choy, cabbage, and kale—are part of the cruciferous family of vegetables, a category many people associate with broccoli and cauliflower. Cruciferous veggies are some of the best sources of glucosinolates, which may help protect against cancer, including breast, colon, and pancreatic cancers, according to the National Cancer Institute. They’re also responsible for the pungent flavor of cruciferous veggies.

## Staying Safe From Bacteria

Leafy greens have been a cause of foodborne illness. There were 192 food poisoning outbreaks linked to leafy green vegetables reported in the U.S. between 1998 and 2016, according to the Centers for Disease Control and Prevention. Most recently, two outbreaks involved romaine lettuce tainted with *E. coli* O157:H7, a dangerous strain that produces a toxin



## TURN OVER A NEW LEAF

---

Those who eat more greens (such as kale, shown here) might have the brain function of someone 11 years younger, research shows.

that in some cases can lead to serious illness, kidney failure, and even death. The second outbreak, which occurred this past spring, sickened more than 200 people across the country, five of whom died. (Government agencies declared this outbreak over in June.)

According to James E. Rogers, Ph.D., director of food safety research and testing at Consumer Reports, if E. coli (or any other type of bacteria that can cause food poisoning) is present in your produce, washing it won't remove all the organisms. And it doesn't take much bacteria to make you sick.

"It is very difficult to remove bacteria from leafy greens," Rogers says. "Bacteria have the ability to adhere to the surface of the leaves and to get stuck in microscopic crevices." E. coli bacteria can even find their way into the interior of your produce. "But if you cook the greens until they are fully wilted, they're likely to have

been heated enough to be safe," Rogers says.

Don't let this scare you away from eating leafy greens. During an outbreak you'll want to avoid them, but at other times the risk is lower, Rogers says. He suggests signing up for the Food and Drug Administration's recalls and safety alerts at [fda.gov/safety/recalls/default.htm](http://fda.gov/safety/recalls/default.htm) or following the agency on Twitter @FDAfood to stay on top of news about outbreaks.

### Best Ways to Prep and Pair

How you prepare leafy greens can make a difference in the amount of nutritional benefit you get. For instance, boiling cruciferous veggies can leach some of their glucosinolates into the water, according to Keating, so a quick steam or stir-fry is best.

For other greens, cooking enhances their nutrition quotient. Take spinach: It contains calcium and iron, but our bodies can't absorb

as much of those nutrients from raw spinach as it can when the greens are cooked. Quickly blanching spinach is one of several cooking methods that appear to make more of the vegetable's calcium and iron available for the body to use.

What you eat with greens matters, too. For example, you'll get more iron from plant foods, including chard, kale, and spinach, if you pair them with a source of vitamin C, such as lemon juice or red bell peppers. And you enhance the absorption of other nutrients, including lutein, in leafy greens when you eat them with a healthy fat, such as olive oil.

### Tasty Meal Options All Day Long

Many people know their way around salad preparation, though it's worth repeating here how nutritious, easy, and delicious salads are, and thus well worth the time it takes to buy, wash, and chop veggies and greens. But you don't have to restrict yourself to salads to work leafy greens into your diet.

#### › Serve as a savory side.

You can sauté any type of green with olive oil, lemon, and garlic as a side dish, or wilt sturdier greens, such as kale and chard, by pouring a warm vinaigrette dressing over them. Or try making kale chips. Toss the leaves with some olive oil, and sprinkle with a bit of salt.

Bake on a cookie sheet in a 375° F oven for 5 minutes, toss again, and bake for 7 to 9 more minutes.

› **Garnish sandwiches and wraps.** Consider adding arugula, kale, spinach, or another dark green to your lunch. A few leaves here and there throughout the day can move you toward your daily greens goal.

› **Mix them in.** Add greens to soups, omelets, and other egg dishes. Or toss them into your pasta cooking water just 2 minutes before you drain the pasta, or wilt them in marinara sauce, says Claudia Gallo, a chef and food tester at CR. If leafy greens are a tough sell for your palate, use a food processor to chop them finely and mix them into turkey burgers, meatloaf, meatballs, or casseroles. You can throw a handful of spinach or kale leaves into the blender when making a fruit smoothie; the fruit will mask the somewhat bitter taste of the greens. You can even add puréed spinach leaves to brownie, muffin, or pancake batter.

#### › Make smart substitutions.

Instead of a tortilla with a taco or wrap, use leaves of lettuce for your sandwich. If you're making pesto, try substituting some of the basil with another flavorful green, such as arugula or kale. The American Heart Association suggests slicing Swiss chard into ribbons, sautéing, and using in place of rice as a bed for seafood.



### TRY IT GRILLED!

Pump up the natural sweetness of a summer fruit or veggie by grilling it. For kebabs, the pieces on each skewer should be about the same size and thickness for even cooking. Stone fruits such as peaches, nectarines, and plums are especially tasty when grilled. Slice in half, remove the pit, and brush with a dab of vegetable oil. Grill cut-side down over medium heat.



For information about our advocacy efforts for safer produce, see "Keeping Leafy Greens Safe," on page 7.



# Fruit & Veggie Superpowers

## FRUITS



**BLUEBERRIES**

Low in calories, blueberries are also packed with anthocyanins, powerful antioxidants that fight cell damage and reduce inflammation. Some research suggests that these berries bolster brain function, so eating them may help keep your memory sharp.



**CHERRIES**

One cup of cherries has just 87 calories and packs 306 mg of potassium—a blood-pressure-lowering mineral that about 98 percent of Americans don't get enough of. (The daily recommendation is 4,700 mg.)



**RASPBERRIES**

Like other berries, raspberries are rich in brain-boosting anthocyanins. But they have another big benefit: One cup contains 8 grams of fiber, a nutrient that aids digestion and may lower cholesterol, protect against diabetes, and reduce the risk of certain cancers.



**PEACHES**

A medium peach provides more than 10 percent of your daily vitamin C and 285 mg of potassium. Its color comes from the antioxidants beta carotene and lutein. Some research suggests that the antioxidants in peaches may have cancer-fighting properties.



**WATERMELON**

As its name suggests, this fruit is mostly water—91 percent—so it's hydrating. Plus it has vitamins A and C, B vitamins, and potassium, for just 46 calories per cup. It's one of the few sources of the antioxidant lycopene, which may protect against certain cancers and heart disease.

## VEGGIES



**BELL PEPPERS**

Chop up a cup of red bell peppers and you'll get more than twice as much vitamin C as you would in a midsize orange—plus plenty of beta carotene, folate, and fiber.



**CORN**

In addition to fiber, corn contains disease-fighting phytochemicals, as well as the minerals magnesium and potassium. A medium ear has fewer than 100 calories—just be mindful not to slather it in butter and salt.



**EGGPLANT**

That rich purple color comes courtesy of anthocyanins, and eggplant supplies potassium, too. Tip: To keep it from soaking up oil (and extra calories) when you cook it, just spritz with olive oil spray before you grill, roast, or sauté.



**TOMATOES**

A small tomato has just 16 calories. Whether tomatoes are red or yellow, they pack a decent amount of vitamin C. But only the red variety contains the antioxidant lycopene.



**ZUCCHINI**

This favorite of low-carb dieters is not only low in calories but also high in potassium and manganese. Zucchini (and other summer squash) also supplies vitamin C and energy-boosting B vitamins.



# Why You Should Eat More Fish

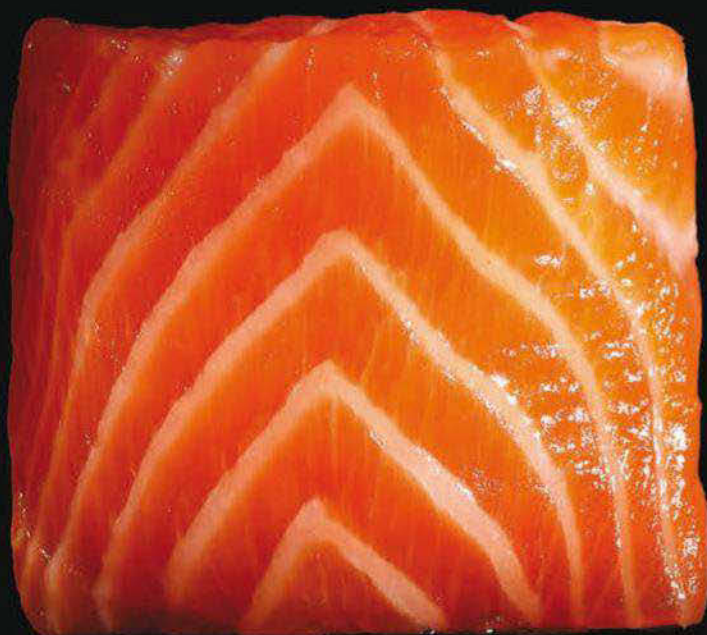

Whether it's grilled salmon, peel-it-yourself shrimp, or a festive clambake, fish and shellfish are often the centerpiece of summer meals. Packed with **LEAN PROTEIN AND LOW IN CALORIES**, seafood is one of the best things you can put on your plate. It's also the richest source of omega-3 fatty acids, a type of polyunsaturated fat that is important for heart and brain health.

## A Heart-Healthy Habit

"Omega-3s are important for cell communication in heart muscle and for cells within the lining of the arteries," says Eric B. Rimm, Sc.D., professor of epidemiology and nutrition at the Harvard T.H. Chan School of Public Health in Boston. These fats may reduce harmful inflammation throughout the body, prevent heart rhythm problems, improve the flexibility of arteries, and lower cholesterol.

For all these reasons, the American Heart Association recommends eating at least two weekly servings of nonfried fish—especially fatty fish—to get these benefits. A serving is about 3½ ounces of cooked fish or ¾ cup of flaked fish (such as tuna or canned salmon). This past spring, the AHA ratified this 16-year-old recommendation in a new advisory based on a review of the latest research.

"There is substantially more evidence now pointing to seafood intake and lower risk of coronary heart disease and sudden cardiac death—especially when the seafood replaces less healthy main dishes such as beef or pork," says Rimm, who is the chair of the AHA's writing group. Among the key findings:

- People who ate one to two fatty-fish meals a week had a 50 percent lower risk of sudden cardiac death than those who ate little or no seafood.
- Those who ate one serving of fish a week had a 14 percent lower risk of ischemic stroke (the type caused by a blood clot in the brain) than people who ate little or no fish.

PHOTO: ISTOCK



► People who consumed seafood four or more times a week had a 22 percent lower risk of coronary heart disease overall than those who ate it less than once a month.

It's possible that going beyond the recommended two servings a week could provide additional health benefits. But hard evidence is lacking. "There just aren't a lot of studies that included consumption at higher levels," Rimm says.

Based on the available evidence, the researchers concluded that much of the benefit comes from moving from very little or no fish in the diet to eating fish once or twice a week. "However, if fish is consumed four or more times a week as a substitution for other, less healthy foods, then I do think that more is better," Rimm says.

### Mind Your Mercury

One downside of increasing the amount of fish you eat is potential exposure to mercury, a toxin that can affect brain development in fetuses and young children, and in excess may affect the health of adults as well.

"It's healthy to eat fish, and you can even eat a lot of fish. You just need to pay attention to which fish are high or low in mercury," says Jean Halloran, director of food policy initiatives at Consumers Union, the advocacy division of Consumer Reports. "There are acute neurological risks of too much mercury, even for adults—from cognitive issues to tremors and loss of balance."

The heavy metal is in the ocean from mercury released

by coal-fired power plants and other industrial or natural sources, such as volcanoes. Mercury-containing plants and tiny animals are eaten by smaller fish that are then gobbled up by larger fish, whose tissue accumulates mercury. That's why larger, longer-living predators such as sharks and swordfish tend to have more of the toxin than smaller fish such as sardines, sole, and trout. Bigeye tuna (often used in sushi), Gulf tilefish, king mackerel, marlin, and orange roughy are other high-mercury fish.

Some of the fish that are low in mercury—Atlantic mackerel, salmon (including canned), sardines, trout—are rich sources of omega-3s. "Other low-mercury fish—such as catfish, flounder, tilapia, shrimp, and sole—supply less omega-3s, but they still can contribute to your overall intake," Halloran says.

As for canned tuna, Halloran says previous Consumer Reports analyses of mercury levels in tuna suggest that pregnant women shouldn't eat it at all. Everyone else should opt for chunk light, which has one-third of the mercury of albacore and about one-fifth of the mercury in sushi tuna, and not make canned tuna the only type of seafood they eat.

### Fish Safety 101

Like many foods, fish and shellfish could carry pathogens that can make you sick, including bacteria such as salmonella and vibrio vulnificus, and occasionally viruses.

"In my opinion, seafood is unique because some of

it, such as oysters, is eaten raw, and other seafood is not cooked with as much heat and time as you would cook chicken, for instance," says James E. Rogers, Ph.D., director of food safety research and testing at Consumer Reports.

For most people, a bout with foodborne illness is unpleasant but short-term, causing symptoms that range from a mild stomach upset to cramping, diarrhea, and vomiting.

"If you have a healthy immune system, it might just be an uncomfortable 24 hours," says Lauri Wright, Ph.D., R.D.N., an assistant professor of nutrition and dietetics at the University of North Florida and a spokesperson for the Academy of Nutrition and Dietetics. "But for young children, older adults, and people whose immune system is compromised by health problems such as diabetes or liver disease, it could lead to hospitalization or even, in rare cases, to death."

Here's what experts advise to help you ensure that you're serving safe seafood.

► **Reconsider raw fish.** In addition to sushi, this includes ceviche, seafood marinated in lemon or lime juice long enough for acids to turn the flesh white. "It looks cooked, but it really isn't," Wright says. Raw clams and oysters can carry vibrio vulnificus, which in some cases can be deadly. According to the Food and Drug Administration, avoiding fish from polluted waters is not a guarantee

that you won't get sick, and neither is abiding by the common misconception that it's safe to eat raw shellfish in months that contain the letter "r." And contrary to popular belief, hot sauce and alcohol do not kill bacteria that cause foodborne illness.

### ► Be temperature-conscious.

Cook seafood to an internal temperature of 145° F. For thicker fish, such as a salmon steak, slip an instant-read food thermometer (preferably a digital one) into a side of the fillet. For shellfish or a delicate fillet of sole, the Department of Agriculture says it's also safe to cook fish until the flesh is opaque and flakes easily with a fork. Cook crabs, lobster, and shrimp until the flesh is opaque and pearly; clams, mussels, and oysters until their shells open; and scallops until they're milky white or firm and opaque. Refrigerate cooked seafood dishes within an hour or two of serving. If you're serving seafood cold, as in a shrimp cocktail or salad, keep it refrigerated until you're ready to eat it. For picnics or buffets, place the serving dish in a bowl of ice, so the fish stays cool, Wright says.

► **When in doubt, throw it out.** "If you don't know—or cannot trust—how your seafood has been stored before it's cooked or maintained after cooking, it is better to dispose of it," Rogers says. "Seafood can be pricey, but getting sick can be as well." Toss leftover cooked seafood after two days in the fridge.



# Staying Happy, Healthy & Hydrated

Staying hydrated regulates body temperature, allows your heart to work more efficiently, prevents **HEADACHES** and muscle fatigue, aids with **DIGESTION**, and even **BOOSTS YOUR MOOD**. But in the heat of summer, it's easy to become dehydrated without realizing it.

You might be tempted to try one of the many sports drinks or flavored waters on supermarket shelves, thinking they're a step up from plain old H<sub>2</sub>O.

What's the truth? CR's nutritionists took a closer look at the types of hydration drinks on the market. Here's their verdict.

## SPORTS DRINKS

These were originally developed for hard-core athletes to replenish electrolytes, such as sodium and potassium, that are lost in sweat, plus carbohydrates that muscles use for fuel. "The average exerciser needs to replace water, not electrolytes," says Amy

Keating, R.D., a CR nutritionist.

Worse, sports drinks could offset the calorie-burning benefits of exercise. "A person who weighs 150 pounds will burn around 150 calories in 30 minutes of brisk walking, but sports drinks can have about 100 calories in 16 ounces," Keating says. Zero-calorie and low-calorie sports drinks might not have any (or as much) sugar but may have artificial sweeteners. And both types might have artificial colors or other added ingredients.

## WATER WITH ADDED VITAMINS

There's no need to replenish vitamins just because it's hot out or you went for a run. And if you drink a lot of these, you run the risk of overloading on vitamins, especially if you take a multivitamin and/or eat vitamin-fortified foods, such as certain cereals. Also, read labels—some products are full of sugars.

## PLANT WATERS

Labeling on certain coconut, maple, cactus, and other trendy plant waters suggests that these drinks are more hydrating than water or a more natural alternative to sports drinks.

There's not much truth to the hydration claims, but they are lower in sugars. Coconut water has about 40 to 65 calories and 9 to 14 grams of sugars in 8 ounces; cactus and maple have about 25 calories and 5 grams of sugars in 8 ounces.

## ICE TEA

Brewed tea has negligible calories and contains antioxidants that may improve heart health and lower the risk of cognitive decline and type 2 diabetes. But when it comes in a bottle, tea might not have any of these benefits.

Many bottled ice teas are

nutritionally on a par with soda—containing loads of sugars. Diet ice teas will be low in sugars and calories, but they may have artificial sweeteners, such as aspartame and sucralose.

Instead, look for ice teas labeled "unsweetened." "You can add a teaspoon of sugar or agave syrup and get far less sugars than in many presweetened versions," Keating says.

If you want antioxidants, brew up a pitcher. "Bottled teas are very low in antioxidants compared to freshly brewed tea," says Joe Vinson, Ph.D., professor emeritus of chemistry at the University of Scranton, whose lab has analyzed a variety of teas. But the antioxidants dissipate over time. "We found that once brewed, the antioxidant content went down about 10 percent a day," Vinson says. So don't make a bigger batch than you can drink in a day or two.

## HOMEMADE ALTERNATIVES

Do-it-yourself flavored waters are a healthy and tasty alternative to bottled drinks. Start with a large pitcher of ice water and add sliced fruit. Or try the idea below from Chad Luethje, executive chef at Red Mountain Resort in southwest Utah.

## GINGER-PEACH COOLER

Add 2 quartered peaches (or another stone fruit) and about 2 inches of peeled ginger root, thinly sliced. Fill pitcher with water and stir gently. Add fresh lemon verbena leaves or lemongrass stalks, if desired.



# Smart Shopping at the Farmers Market

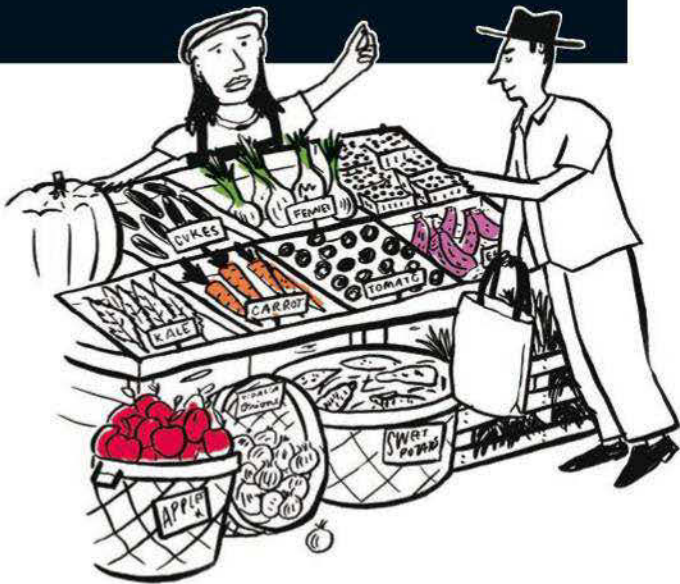

It's easy to understand why farmers markets are popular: They offer **FRESH LOCAL PRODUCE**, plus a chance to meet the people who grow what you're buying. But it's not always clear to shoppers whether the produce heaped up all around is local, organic, or both.

For starters, consumers need to know that local and organic are not the same thing. "In order to call your produce organic, you [the farmer] have to be certified by the USDA," says Joe Masabni, Ph.D., a vegetable specialist at the Texas A&M AgriLife Research & Extension Center in Overton. "There is paperwork to fill out, processes to follow, and you have to be approved." A certification agency accredited by the Department of Agriculture checks annually to make sure the farm is complying with organic standards. The exception: Farmers with yearly sales of less than \$5,000 do not need to be certified to use the term organic.

Organic growers are prohibited from using most synthetic pesticides and fertilizers, as well as antibiotics (which conventional farmers may use on animals and certain fruit trees). Organic farmers also must take measures to protect water and soil quality.

The USDA Organic seal is "your guarantee that the food you're buying was produced in ways that minimize harm to health or the environment," says Charlotte Vallaeys, senior policy analyst at Consumer Reports and a sustainability expert.

As to the question of what "local" means, the USDA says that more than 85 percent of vendors at farmers markets come from within 50 miles of their location. Markets often permit growers only from a certain geographical radius and can be strict about people selling only what they've produced. But others allow vendors to sell products they haven't grown or produced themselves. Every farmers market sets its own rules and has a manager, so if these issues matter to you, ask the manager for details.

Ideally, Vallaeys says, you'd buy fruits and vegetables that are local and certified organic. But if the food is just grown locally (and doesn't have that organic seal), buying it still has many advantages.

Consider the fact that although many supermarkets carry local

produce, much of what you find at stores has been transported 1,200 miles, on average. Produce at farmers markets is often picked ripe and sold within a day. That translates into fresher, more nutritious food because the vitamins and other nutrients haven't had time to break down," says Lauri Wright, Ph.D., R.D.N., assistant professor of nutrition and dietetics at the University of North Florida.

## HOW TO AFFORD ORGANIC

Farmers markets often get a bad rap for being expensive, but Wright says that's not necessarily true. "They're selling what's in season and plentiful, so often they're able to sell it at great prices," she says. "Plus, produce that hasn't been sitting in a truck for days will last longer, and that can save you money by reducing food waste."

Here are other ways to help you afford organics.

➤ **If you're a fan of, say, the baby-cut carrots you see in supermarkets**, know that you are paying a premium for whole large carrots to be peeled and cut into small pieces. Organic whole carrots tend to be less expensive than the nonorganic baby-cut variety.

➤ **Snack on organic fruits and vegetables.** USDA researchers have found that fresh produce often costs less than sweet and salty snacks.

➤ **Buy a 'share' in a farm program.** When you join a CSA (community supported agriculture) program, you pay the farmer at the start of the season. Then you receive a share of the harvest weekly or biweekly throughout the season. In this system, you're likely to spend less than you would if you bought the same goods at the store. Worried you'll have more fruits and vegetables than you know what to do with? You can also preserve them for the winter months by canning, drying, or freezing.

# THE DIRT ON DISHWASHERS



Whirlpool  
WDF540PADM  
\$520

81

OVERALL  
SCORE

NEW MODELS CLEAN BETTER AND MORE QUIETLY—EVEN WHILE THEY USE LESS WATER AND ENERGY. OUR NEW RATINGS WILL STEER YOU TO A CHOICE THAT WILL FIT YOUR BUDGET AND LAST AS LONG AS YOU EXPECT. by Kimberly Janeway



## NO MORE DRIPPY DISHES

Some dishwashers have a tough time drying because water pools in concave areas of glasses and can't evaporate quickly, and because of the interior humidity, says Larry Ciufo, CR's dishwasher test engineer.

To improve matters, add a rinse aid to the dedicated dispenser. These formulas break the bond between water molecules and dishes. Allowing ample space between dishes for air to circulate also aids drying.

**THE DISHWASHER MIGHT** be the appliance we're most guilty of taking for granted. But if you've stayed in a vacation rental without one or suddenly had your machine konk out, you'll long for it as you're wrist-deep in sudsy water. And if you ever wondered how much time dishwashers save you vs. washing dishes by hand, Energy Star has calculated just that: about 230 hours per year.

Today's dishwashers use 4 to 6 gallons of water to clean a full load compared with 10 gallons a decade ago. Most of the ones we test are Energy Star certified—they'll save nearly 5,000 gallons of water per year and use less than half as much energy as washing dishes manually, according to Energy Star. And many new models are quieter than their predecessors thanks to better insulation.

But that's not all that's changed. Some manufacturers have modernized the look, moving controls to the top edge of the door (so they're hidden from view when the door is closed), ditching the brand logo, and replacing the bar handle with a recessed pocket. With no logo or handle, a stainless dishwasher from any manufacturer can fit seamlessly into a kitchen with stainless appliances from other brands.

When shopping, take a close look at how the dishwasher's interior is configured. More space between the tines allows you to fit bigger plates and bowls, for example. Can you move the silverware basket? A flexible design that works with the way you cook is ideal. So take two of your everyday plates and a bowl with you.

Whether your dishwasher bit the dust or you're unhappy with its cleaning capabilities—or you're simply ready for an upgrade, given the above—we've got new and improved ratings, beginning on page 41, that combine our test results with survey data for predicted reliability and owner satisfaction.

## The Most Reliable Brands

In Consumer Reports' latest dishwasher survey, we asked CR members about the 74,880 appliances they purchased between 2007 and 2017. The eight brands below represent, in order, the most reliable in our survey, rated either Excellent or Very Good for predicted reliability. (You'll see ratings for this, along with those for owner satisfaction, in our charts beginning on page 41.) If reliability is your top concern, look for a model from one of the top-tier brands.

### PREDICTED RELIABILITY



Source: Consumer Reports' 2017 Spring Dishwasher Survey.

## What Your Money Can Buy

**FOR \$500 OR LESS.** "You don't have to spend a ton to get top-tier performance," says Larry Ciuffo, the CR engineer who runs our dishwasher tests. Some appliances that sell for \$500 or less earned an Excellent in our cleaning test. "And some ace drying, an even more difficult task." But at lower prices, wash times can be longer and most machines are relatively noisy.

Another consideration: soil sensors. These devices improve cleaning and water efficiency by adjusting the cycle time and amount of wash water based on each load's soil level. But not all basic machines have this feature. And stainless tubs, which resist stains better than plastic, aren't a given.

**FOR \$600 TO \$900.** "Move up to this price range and you will get more peace and quiet while your dishwasher is running," says Min Kim Bryant, a senior market analyst at CR. "Sleeker styling and convenience features, such as express cycles that quickly clean lightly soiled items, also might make it worth spending more." Expect a stainless interior, more finish options (including black stainless), and adjustable racks that can shift up or down to accommodate large and odd-shaped items. You'll see more models with hidden controls, special wash zones for reusable water bottles or pots and pans, and a third rack up top that allows you to spread out large utensils.

**FOR \$1,000 AND UP.** "These dishwashers come with useful and innovative features," says Bryant. We've seen models with LEDs that shine light on the dishes when you open the door. WiFi-connected dishwashers allow you to control your machine from your smart phone and receive updates on cycle status.

At this upper tier, you'll see more European brands, and their rack configuration may differ from U.S. brands. Again, this may affect how your dishes fit in the dishwasher.



## How to Give Your Dishwasher Staying Power

**VARIOUS DISHWASHER** manufacturers tell us their appliances are built to last roughly 10 years. That lines up nicely with the average length of time people expect theirs to last, according to Consumer Reports' latest dishwasher survey. But many factors can affect a dishwasher's lifespan, including how you treat it every day.

**Scrape-Don't Rinse-Plates**  
Of course you don't want bones, toothpicks, and globs of food going into the dishwasher, but there's no need to rinse plates. In fact, if the soil sensor detects little or no debris, a lighter wash will follow, possibly leaving your dishes dirty.

**Stick to Safe Materials**  
That jar of jelly you want to recycle? Hand-wash it.

Labels on glass jars can become unglued during a trip through the dishwasher, clogging the filter and jamming the pump.  
Not all plastics are dishwasher-safe. Some will melt in a dishwasher, and pieces can break off and wind up in the filter, damaging it. If the plastic is labeled dishwasher-safe, place it on the top rack,

and skip cycles that use higher wash or dry temps, such as the sanitize cycle. Higher heat can cause harmful chemicals such as phthalates and BPA to leach from plastics that contain them.

**Always Run Full Loads**  
"Dishwashers have mechanical parts, and the more you use the dishwasher, the faster those parts will wear out," says Larry Ciufo, the engineer who runs CR's dishwasher tests. To reduce the number of cycles, run full loads rather than partial ones.

**Avoid Strong Chemicals**  
Chlorine bleach and degreasing agents can affect how long key components (such as the hydraulic circuits, pump, and seals) last.

**Add Salt if You Have Hard Water**  
If your dishwasher has a built-in water softener, use a regeneration salt following your manual's instructions. This improves cleaning, helping to prevent spotting and clouding. The salt also helps prevent mineral buildup in the dishwasher.

**Be Mindful to Keep It Clean**  
Run the clean-dishwasher cycle as often as your manual specifies. Regularly rinse away food stuck in the manual-clean filter, and wipe away food trapped between the door and gasket.

# What's the Strangest Thing You've Ever Put in Your Dishwasher?

We put this question to our members and also queried manufacturers. They confessed to some pretty weird items, including fish and car parts. But putting things in a dishwasher that aren't deemed dishwasher-safe can damage the item, the dishwasher—or both.



## CAR PARTS

Some members have tried to clean hubcaps, racing-auto valves, and vintage wheel covers. But grease from machinery can clog the wash system, preventing water from circulating and shortening a dishwasher's life.



## USED PAINTBRUSHES

The chemicals in paint (especially the oil-based type) can damage key dishwasher parts, such as the filter and pump. Those chemicals can also wind up in a dishwasher's water line and land on dishes and glasses.



## GARDEN TOOLS

Soil on garden tools can damage dishwasher components. These appliances are designed and tested to handle small food particles, detergent, and rinse aids. That's it.



## BRAS

With no agitation and no tumbling, you can sort of understand why someone might be tempted to put bras in a dishwasher. But the heat can damage them, and dishwasher detergents aren't ideal for cleaning delicates because they often contain degreasers and bleach.



## CAST-IRON COOKWARE

Seasoning and baked-on oil help form a slick surface for cooking and prevent rust—but a dishwasher removes it.



## COMPUTER KEYBOARDS

Even if the keys come out clean, water might linger inside and damage the keyboard's functionality.



## CROCS

It might seem like the easiest way to clean these plastic slip-on shoes, but a dishwasher's heat can shrink or warp Crocs.



## FISH

Some people "cook" salmon wrapped in foil in their dishwasher. But it's questionable whether certain foods (like fish and eggs) are heated well enough to kill microorganisms such as salmonella.



## INSULATED MUGS

Water and high temps can damage the vacuum seal between the inner and outer layers. And once water gets in that seal, it can affect the mug's ability to retain heat.



## DISHES WITH GOLD LEAF, BRASS, OR BRONZE

Discoloration or fading are both possibilities with any gold-leaf detailing on dishes or china. High temps and detergent can discolor or pit brass and bronze. The same is true for copper and pewter.



## SHARP KNIVES

They can become dull after rubbing against other cutlery in the basket. Some dishwashers have a top rack for large utensils, but we still advise hand-washing good knives.



## WOODEN ITEMS

Wood, water, and heat aren't a great mix; wood cutting boards, salad bowls, and utensils can warp or crack.



**Ratings** > **Clean Machines** Our new Overall Score for dishwashers incorporates predicted reliability and owner satisfaction from our surveys with performance test results. The dishwashers below are all Energy Star certified, so check online for utility rebates.

Recommended	Rank	Brand & Product	Overall Score	Price	Survey Results		Test Results					Features			
					Predicted reliability	Owner satisfaction	Washing	Drying	Energy use	Water use	Noise	Cycle time (min.)	Hidden controls	Interior	Self-cleaning filter
CONVENTIONAL DISHWASHERS															
👍	1	Bosch Ascenta SHX3AR75UC	88	\$540	👍	👍	👍	👍	👍	👍	👍	95	All	Stainless/plastic	
👍	2	KitchenAid KDTM354DSS	83	\$900	👎	👍	👍	👍	👍	👍	👍	125	All	Stainless	•
👍	3	Bosch 300 Series SHEM63W55N	82	\$720	👍	👍	👍	👍	👍	👍	👍	155	None	Stainless	•
👍	4	Kenmore 14573	81	\$650	👍	👎	👍	👍	👍	👍	👍	145	All	Stainless	•
👍	5	Kenmore 14543	81	\$700	👍	👎	👍	👍	👍	👍	👍	145	All	Stainless	•
👍	6	Kenmore Elite 12793	81	\$1,335	👍	👎	👍	👎	👍	👍	👍	145	All	Stainless	
👍	7	Whirlpool WDF540PADM	81	\$520	👍	👎	👍	👍	👍	👍	👎	115	None	Plastic	
	8	Kenmore 14523	80	\$650	👍	👎	👍	👍	👍	👍	👍	150	None	Stainless	
	9	KitchenAid KDTM704ESS	80	\$1,645	👎	👍	👍	👎	👍	👍	👍	110	All	Stainless	•
	10	Kenmore Elite 14833	79	\$1,710	👍	👎	👍	👎	👍	👍	👍	115	All	Stainless	•
	11	Bosch 800 Series SHPM78W55N	79	\$855	👍	👍	👍	👍	👍	👍	👍	160	All	Stainless	•
	12	Ikea Renlig IUD8555DX [20288920]	78	\$800	👍	👎	👍	👍	👍	👍	👍	145	All	Stainless	
	13	Kenmore Elite 14793	78	\$900	👍	👎	👍	👎	👍	👍	👍	145	All	Stainless	•
	14	KitchenAid KDTM404ESS	78	\$1,215	👎	👍	👍	👎	👍	👍	👍	110	All	Stainless	•
	15	Bosch 800 Series SHXM98W75N	78	\$1,080	👍	👍	👍	👎	👍	👍	👍	160	All	Stainless	•
	16	Kenmore Elite 14753	78	\$700	👍	👎	👍	👎	👍	👍	👍	145	All	Stainless	•
	17	GE Profile PDF820SSJSS	77	\$1,015	👍	👎	👍	👎	👍	👍	👍	150	None	Stainless	•
	18	Kenmore 13223	77	\$500	👍	👎	👍	👍	👍	👍	👎	160	None	Stainless	•
	19	Miele Futura Crystal G6665SCVISF	76	\$1600	👍	👍	👍	👍	👍	👍	👍	140	All	Stainless	•
	20	Bosch 500 Series SHPM65W55N	76	\$810	👍	👍	👍	👎	👍	👍	👍	160	All	Stainless	•
	21	Kenmore 13473	76	\$450	👍	👎	👍	👍	👍	👍	👎	160	All	Plastic	•
	22	GE Profile PDT855SSJSS	76	\$1350	👍	👎	👍	👎	👍	👍	👍	155	All	Stainless	
	23	Bertazzoni DW24XT	75	\$1,065	–	–	👍	👎	👍	👍	👍	135	All	Stainless	•
	24	Equator ST6501	75	\$660	–	–	👍	👎	👍	👍	👍	135	None	Stainless	•
	25	Amana ADB1700ADS	75	\$440	👍	👎	👍	👎	👍	👍	👎	145	None	Stainless	•
	26	Thor Kitchen HDW2401SS	75	\$700	–	–	👍	👎	👍	👍	👍	130	All	Stainless	•
	27	KitchenAid KDPE234GPS	74	\$770	👎	👍	👍	👎	👍	👍	👍	135	All	Stainless	
	28	KitchenAid KDTE304GPS	74	\$970	👎	👍	👍	👎	👍	👍	👍	135	All	Stainless	

Recommended	Rank	Brand & Product	Overall Score	Price	Survey Results		Test Results					Features			
					Predicted reliability	Owner satisfaction	Washing	Drying	Energy use	Water use	Noise	Cycle time (min.)	Hidden controls	Interior	Self-cleaning filter
CONVENTIONAL DISHWASHERS <i>Continued</i>															
	29	Kucht K6502D	74	\$800	—	—	↑	↓	↑	↑	↑	140	All	Stainless	•
	30	Miele Dimension G6785SCVISF	74	\$1,700	↑	↑	↑	↑	↑	↑	↑	145	All	Stainless	•
	31	Maytag MDB8979SFZ	73	\$810	↓	↓	↑	↑	↑	↑	↑	155	All	Stainless	•
	32	Blomberg DWT25502SS	73	\$500	↓	↓	↑	↑	↑	↑	↓	110	None	Stainless	•
	33	Beko DUT25400X	73	\$540	↓	↓	↑	↑	↑	↑	↓	110	None	Stainless	•
	34	Whirlpool WDT730PAHZ	73	\$450	↑	↓	↑	↑	↑	↑	↑	140	All	Stainless/plastic	•
	35	GE GDT545PSJSS	72	\$500	↑	↓	↑	↓	↑	↑	↓	150	All	Plastic	•
	36	Blomberg DWT56502SS	71	\$630	↓	↓	↑	↓	↑	↑	↓	110	All	Stainless	•
	37	Beko DDT25400X	71	\$540	↓	↓	↑	↓	↑	↑	↓	110	All	Stainless	•
	38	Whirlpool WDF330PAHS	71	\$435	↑	↓	↑	↓	↑	↑	↓	110	None	Plastic	•
	39	GE GDT635HSJSS	71	\$695	↑	↓	↑	↓	↑	↑	↓	155	All	Stainless/plastic	•
	40	LG LDT7808BM	70	\$1,000	↓	↓	↑	↑	↑	↑	↑	145	All	Stainless	•
	41	Whirlpool WDT970SAHZ	70	\$650	↑	↓	↑	↑	↑	↓	↑	145	All	Stainless	•
	42	Kenmore Elite 14815	70	\$1,050	↑	↓	↑	↓	↑	↑	↑	120	All	Stainless	•
	43	Samsung DW80K7050US	70	\$700	↓	↓	↑	↑	↑	↑	↑	130	All	Stainless	•
	44	Bosch 800 Series SHEM78WH5N	68	\$1,185	↑	↑	↑	↓	↑	↑	↑	165	All	Stainless	•
	45	Ikea Renlig IUD7555DS [90292264]	68	\$500	↑	↓	↑	↓	↑	↑	↑	160	All	Stainless	•

**HOW WE RATE DISHWASHERS:** Overall Score combines performance test results with survey data for predicted reliability and owner satisfaction, and is based on a 100-point scale. Predicted reliability estimates the likelihood that newly purchased models from a given brand, not under service contract, will break

within the first five years. Owner satisfaction reflects the proportion of CR members who are extremely likely to recommend the dishwasher they bought to friends and family. In cases where we have insufficient data to provide a brand-level rating, as indicated by a gray dash (—), we assume the model has average

reliability and satisfaction. To score Washing performance, we run the normal or equivalent cycle to clean a full load with 10 place settings. (More information below.) Drying performance is our assessment of how thoroughly a dishwasher dries plastic cups—a tough task—using our test cycle and a rinse aid, which

improves drying. Energy and Water use is based on our test cycle. A panel of testers judge Noise levels by listening to each machine through its entire cycle. Cycle time, rounded to the nearest 5 minutes, is based on running the normal or equivalent cycle to clean a full load. Price is approximate retail.

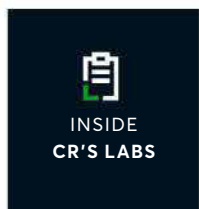

We spend 28 hours evaluating each dishwasher. Our engineers smear a mix of cola, flour, shortening, cocoa, and powdered egg yolk on white ceramic dishes. They bake on the mess in an oven, allow the dishes to cool, and photograph them. Testers then load each machine with 10 place settings of dishes, glasses, and flatware, and run it on the normal cycle. The "before" and "after" versions are compared to determine the dishwasher's cleaning score.



CR test engineer Larry Ciufa

**Ratings** > **Super Powers** More single-dose detergents packs contain a pretreat solution, degreaser, bleach, or rinse aid, making them our top performers.

		Brand & Product	Overall Score	Price per Load	Test Results						Specs	
Recommended	Rank				Size of package	Cleans dishes	Cleans pots	Resists water spots	Resists food deposits	Resists film/discoloration	Contains bleach	Contains enzymes
SINGLE-DOSE												
✓	1	<b>Kirkland Signature</b> (Costco) Premium Dishwasher Pacs	85	11¢	115 ct.	⬆️	⬆️	⬆️	⬆️	⬆️	•	•
✓	2	<b>Member's Mark</b> Ultimate Clean Dishwasher Pacs (Sam's Club)	83	10¢	105 ct.	⬆️	⬆️	⬆️	⬆️	⬆️	•	•
✓	3	<b>Finish</b> Quantum Max Powerball	83	41¢	14 ct.	⬆️	⬆️	⬆️	⬆️	⬆️	•	•
✓	4	<b>Finish</b> Powerball Tabs	82	18¢	32 ct.	⬆️	⬆️	⬆️	⬆️	⬆️	•	•
✓	5	<b>Cascade</b> Complete ActionPacs With Dawn	82	30¢	23 ct.	⬆️	⬆️	⬆️	⬆️	⬆️	•	•
✓	6	<b>Cascade</b> Platinum ActionPacs With the Power of Clorox	82	34¢	36 ct.	⬆️	⬆️	⬆️	⬆️	⬆️	•	•
✓	7	<b>Finish</b> Gelpacs	82	21¢	20 ct.	⬆️	⬆️	⬆️	⬆️	⬆️	•	•
✓	8	<b>Up &amp; Up</b> (Target) Advanced Dishwasher Packs	81	18¢	48 ct.	⬆️	⬆️	⬆️	⬆️	⬆️	•	•
	9	<b>Cascade</b> ActionPacs With Dawn	79	23¢	20 ct.	⬆️	⬆️	⬆️	⬆️	⬆️	•	•
	10	<b>Great Value</b> Powder Pacs (Walmart)	79	17¢	20 ct.	⬆️	⬆️	⬆️	⬆️	⬆️	•	•
	11	<b>Cascade</b> Platinum ActionPacs With Dawn	79	39¢	14 ct.	⬆️	⬆️	⬆️	⬆️	⬆️	•	•
	12	<b>Seventh Generation</b> Ultra Power Plus Packs	79	26¢	43 ct.	⬆️	⬆️	⬆️	⬆️	⬆️	•	•
	13	<b>Finish</b> Max in 1 Powerball	78	17¢	27 ct.	⬆️	⬆️	⬆️	⬆️	⬆️	•	•
	14	<b>Kirkland Signature</b> (Costco) Dishwasher Pacs	78	9¢	110 ct.	⬆️	⬆️	⬆️	⬆️	⬆️	•	•
	15	<b>Great Value</b> (Walmart) Automatic Dishwasher Pacs	78	12¢	110 ct.	⬆️	⬆️	⬆️	⬆️	⬆️	•	•
	16	<b>Up &amp; Up</b> (Target) Dishwasher Packs	78	13¢	85 ct.	⬆️	⬆️	⬆️	⬆️	⬆️	•	•
	17	<b>Nice</b> (Walgreens) Packs	77	25¢	15 ct.	⬆️	⬆️	⬆️	⬆️	⬆️	•	•
POWDER												
✓	1	<b>Cascade</b> Complete Powder	79	21¢	45 oz.	⬆️	⬆️	⬆️	⬆️	⬆️	•	•
✓	2	<b>Seventh Generation</b> Powder	77	19¢	45 oz.	⬆️	⬆️	⬆️	⬆️	⬆️	•	•
	3	<b>Nice</b> (Walgreens) Powder	71	10¢	75 oz.	⬆️	⬆️	⬆️	⬆️	⬆️	•	•
GEL												
✓	1	<b>Palmolive</b> Eco+	69	7¢	75 oz.	⬆️	⬆️	⬆️	⬆️	⬆️	•	•
	2	<b>Cascade</b> Complete Gel With the Power of Clorox	58	11¢	75 oz.	⬆️	⬆️	⬆️	⬆️	⬆️	•	•
	3	<b>Finish</b> Gel	34	7¢	75 oz.	⬆️	⬆️	⬆️	⬆️	⬆️	•	•
	4	<b>Up &amp; Up</b> (Target) Dishwashing Gel	33	6¢	75 oz.	⬆️	⬆️	⬆️	⬆️	⬆️	•	•

**HOW WE RATE DISH DETERGENTS:** **Overall Score** combines results from all lab tests and is based on a 100-point scale. To score **Cleans dishes** and **Cleans pots**, we load four identical dishwashers with glasses, bowls, clear glass plates coated with a mix of baked-on food, and

two stainless pots with baked-on mac and cheese. We run the dishwashers using the normal wash cycle. When completed, we use a spectrophotometer to measure how clean each dish is. We repeat this test two more times. To score

**Resists water spots** and **Resists food deposits**, we look for water spots that might form after drying and judge how well the detergent prevents food from redepositing on dishware. In a separate test of repeatedly washing dishware plus pieces of aluminum using the same

detergent in very hard water, we measure any white haze due to mineral deposits and judge any discoloration of the metals to score **Resists film and discoloration**. **Price** is approximate retail per load.

# Sick of Confusing Medical Bills?

Hospital, doctor, and insurance bills riddled with incorrect or unexpected charges are shockingly common—confounding and enraging consumers. Learn why our medical billing system is so broken and what you can do to protect yourself and your finances before, during, and after a medical procedure.

BY PENELOPE WANG





**I**N MAY 2015, Chris Brown, a 32-year-old web developer living in Los Angeles, sought medical help for depression. He was hospitalized for four weeks. The charges for his stay and treatment at one point came to \$33,415. It should have been affordable because of Chris' health insurance coverage. But

the hospital billing department sent a portion of the claim to the wrong division of the insurer. When the hospital didn't get reimbursed, bills ranging from \$140 to more than \$11,000 started arriving at Chris' home.

That simple clerical error set off a two-year medical billing ordeal for Chris, who moved to Modesto, Calif., after his hospitalization to live with his parents. His mother, Sharyn, 65, worked in medical insurance billing before retiring. So she thought she understood the system, but even she was stymied. "I knew enough to know he wasn't getting the reimbursement he was owed," she told Consumer Reports.

Over the next months, Chris and his mom placed scores of calls and sent as many emails to the hospital and

the insurer. Sharyn kept a folder of notes that grew to be inches thick. "Every time I called it was like starting over, having to re-explain everything to a new customer-service rep, and none of them seemed to have clear information on their end."

Meanwhile, the hospital sent Chris' account to a collection agency, though it was eventually removed from collections after the bill was disputed. Dignity Health Northridge Hospital Medical Center, where Chris was treated, declined to comment on the case for this article, citing patient confidentiality.

In spring 2017, an exasperated Sharyn finally reached a customer-service rep in the resolution department at the insurer, Blue Shield of California, who promised to help get the issue sorted out. The rep told Sharyn to write a "special consideration" letter explaining the details of the case—something she had not previously been instructed to do. The rep also found a supervisor in the hospital billing department to look into Chris' situation. In August that year, more than two years after treatment, the hospital acknowledged the billing error and mailed Chris,

who had been making payments, a \$943 refund. Sharyn says the balance is now zero. "We were very fortunate we got someone to help us," Chris says.

## A Broken Billing Process

If the Browns' saga sounds familiar, that's because it's being replayed around the country, as millions of Americans struggle with medical billing problems—everything from inaccurate charges to surprise fees to wrongly denied claims. No one seems to be tracking national data on healthcare billing issues, but problems are exceedingly common. In a recent nationally representative Consumer Reports survey of 1,000 insured adults who incurred a major medical bill in the past two years, two out of three said they had at least one billing issue, such as higher-than-expected charges, unclear statements, and bills arriving months late (see facing page).

And because the medical bills themselves are so confusing—filled with specialized terms and lacking clarity about whether you or your insurer is responsible for payment—millions of Americans give up trying to fight them. According to the CR survey, more than one-third of respondents said they paid bills they weren't sure they owed—20 percent of that group paid more than \$1,000. Among the reasons they gave for doing this: The bill was too confusing, they were uncertain their efforts would make a difference, and they were concerned not paying would hurt their credit record.

"The medical billing system is so inefficient and complicated, people don't even know how to make a dispute," says Martin Gaynor, professor of economics and health policy at Carnegie Mellon University. "They just throw up their hands."

Of course, few Americans can afford to pay medical bills they may not owe—let alone ones they do—and the dysfunctional system is wrecking people's finances. Nearly two out of 10 in the CR survey said their credit score was affected by an

Continued on page 50

'IT TOOK MORE  
THAN A YEAR  
TO GET  
SOMEONE  
TO HELP US,'

SAYS SHARYN BROWN OF MODESTO,  
CALIF., WHO HELPED HER  
SON CHRIS FIGHT A HOSPITAL BILL.



# How Americans Struggle With Medical Bills

In December 2017, Consumer Reports surveyed more than 1,000 insured adults who had major medical expenses (\$500 or more) in the past two years about their medical billing experiences. Among the findings:

## THE WIDESPREAD IMPACT

**67%**

Percentage who had at least one medical billing issue, such as higher-than-expected charges, unclear statements, and bills arriving months late.

Percentage who paid bills they weren't sure they owed.

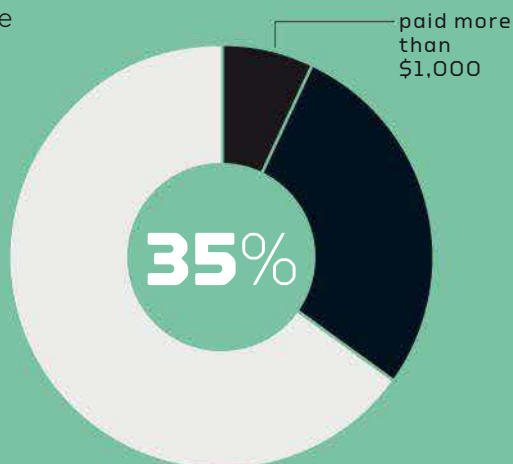

WHY:

**43%**

Thought amount might be correct.

**36%**

Did not think their efforts would make a difference.

**19%**

Concerned that not paying would hurt their credit record.

**10%**

Felt pressured into paying.

## AVOID BILLING SURPRISES

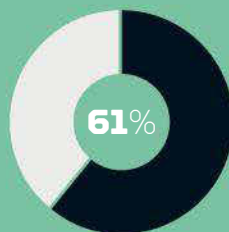

Percentage who tried to make sure the procedure or visit would be covered by insurance.

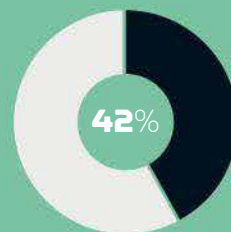

Percentage who tried to find out the cost prior to an office visit.

## THE FIGHT TO FIX THE BILL

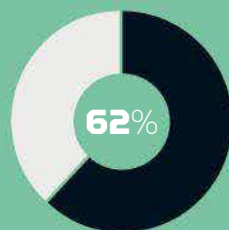

Percentage who took action to resolve a billing issue.\*

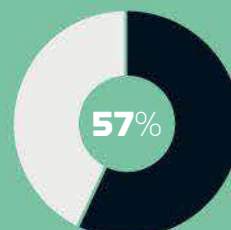

Percentage who had success at negotiating a lower medical bill.\*\*

## THE FINANCIAL FALLOUT

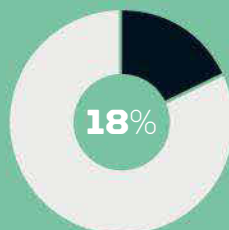

Percentage who say their credit score has been negatively affected by an unpaid medical bill.

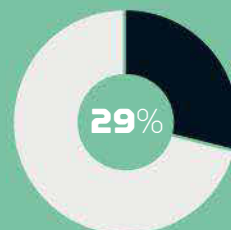

Percentage who say they had unpaid medical bills sent to collections.

\*All respondents who had billing issues. \*\*All respondents who tried to negotiate.

# 6 Ways to Cure Confusing Medical Billing

When it comes to fighting medical bills, consumers are at a disadvantage, because regulatory oversight of health plans is spread among different federal and state agencies. A few states have passed laws that limit surprise fees and ban out-of-network providers from charging you the difference between their fees and the reimbursement amount—a practice known as balance billing. But most states don't have those consumer protections. As a result, consumers are often confused about their options and don't know where to go for help.

That's why Consumer Reports supports A Patient's Financial Bill of Rights that would create a fairer medical billing process (see **"Where We Stand,"** on page 52).

"Consumers need medical bills that are simpler and more accurate, that are consolidated and not sent until insurer payments have been made to providers," says Betsy Imholz, special projects director at Consumers Union, the advocacy division of Consumer Reports.

There's no foolproof way to avoid a medical billing snafu, but there's a lot you can do to minimize the likelihood of problems. "It's important to take advantage of whatever strategies you can," says Carolyn McClanahan, M.D., a certified financial planner in Jacksonville, Fla. So before you go the doctor, and after you start getting those bills, follow these steps.

## BEFORE YOUR VISIT

1

### Know your health plan.

Many billing problems start because people don't understand the basics of their insurance, including deductibles, coverage limits, and the network of providers. "People think they know what plan they have, but they often don't. To be fair, plans change year to year. It's complicated," says Martha Bradt, a health claims advocate in Rye, N.Y.

Make sure your provider has correct insurance information entered in its system. "Many people don't let their doctor know if they've changed jobs, or received a new card, or if there's a secondary payer," says Cindi Gatton, a private patient advocate in Atlanta.

**SMART MOVE:** Grab a cup of coffee and read your health plan document, typically available on your insurer's or employer's benefits website. You'll learn what your plan does and doesn't cover, as well as the limits for treatments—that you're allowed up to 20 physical therapy visits a year, for example.

2

### Try to stay in network.

The best way to avoid billing shocks is to make sure your providers are in your network, McClanahan says. Don't rely on the plan's directory, because those listings could be out of date. Call the doctor's office and give them your plan name and group number to confirm the doctor is in network. Also check to see which area hospitals take your insurance.

With an out-of-network provider, you could be charged more because your visit will be reimbursed by the insurer at a lower rate than with an in-network provider.

**SMART MOVE:** If you're being admitted to the hospital and asked to sign a document of financial responsibility, write in that you agree only if your care is in network, says Elisabeth Rosenthal, M.D., author of "An American Sickness" (Penguin Books, 2018) and editor in chief of Kaiser Health News. That will at least give you a basis for disputing bills later, if you are charged out-of-network fees.

3

### Scout prices in advance.

It's easier to avoid billing surprises if you can determine your charges in advance. In the Consumer Reports survey, only four out of 10 people tried to find out prior to an office visit what the cost would be.



## AFTER YOUR VISIT

That said, it may not be easy to find out prices, but it's worth a try because the cost difference can be huge. That's what Marcy Neely of Cedar Lake, Ind., discovered after she was charged more than \$1,500 for a blood test at a local hospital. When the test needed to be repeated, Neely, 45 and a stay-at-home mom, asked a clerk at the doctor's office what to do. She was referred to a lab that charged just \$270.

To check prices in your area, start with your health plan website—most major insurers offer online tools that show how much you might owe for common procedures and doctor visits based on your deductible status and plan features. You can also ask your doctor what your treatment or procedure is likely to cost, as well as call local providers to see how their prices compare.

**SMART MOVE:** Check out online sources, such as *FAIR Health*, *Clear Health Costs*, or *Healthcare Bluebook*, which can help you determine prices in your area. This information can be helpful if you end up negotiating with a provider (more on that in step 6), because you will know what providers typically charge for that treatment or service.

4

### Wait for the real bill.

"Some providers send bills before they're processed by insurance, followed by more notices," says Arthur Abbie Leibowitz, M.D., chief medical officer of Health Advocate Solutions, an employer benefits firm. "It's so confusing that many people pay what they don't owe, while others wait too long after they get an overdue notice."

To make sure you pay what you actually owe, wait until you get an explanation of benefits (EOB) for that date of service from your insurer. Look to see what the insurance has paid and the amount that is your responsibility, Leibowitz says. At that point, you'll get another bill from the provider reflecting the insurance payment and the amount due from you. The two amounts should be the same. Then you'll know what you really owe.

**SMART MOVE:** Make it a habit to keep organized healthcare records, including receipts, statements, and EOBs. And if you have to call, keep a log of who you spoke to and get a reference number.

5

### Address problems quickly.

If you get a medical bill that seems incorrect, call the provider and your insurer and explain why the bill seems mistaken.

Perhaps the doctor simply entered the wrong code or the insurer didn't receive the bill. If so, ask the provider to resubmit the claim with any necessary corrections. "Many problems can be cleared up with a couple of phone calls," Gatton says.

If that doesn't work, try to diagnose the problem and find out who can solve it. Perhaps your health insurer says a treatment is not covered, but your doctor says it should be. If so, you may need to gather documentation that bolsters your case. "Chances are, your provider will want to help you, since they want to get paid," says Cyndee Weston, executive director of the American Medical Billing Association, a trade group.

Be aware that most providers set a time limit of 60 to 90 days on bill payment, so if there's a dispute, notify the billing office in writing. It can freeze the account for an additional 30 days. Otherwise, your account could be sent to collections. Similarly, you face a time limit on appealing denials to your insurance company, which may be anywhere from 90 to 180 days, says Martine Brousse, a medical billing patient advocate in Culver City, Calif.

**SMART MOVE:** If your efforts aren't getting you anywhere, it may be time to seek help. You can start with your employer's benefits department—about 64 percent of large companies offer patient advocacy help, according to a 2018 survey by the National Business Group on Health, a nonprofit organization. For other options, see "How to Get Help With Your Bills," on page 50.

6

### Consider negotiating.

Sometimes offering to make a deal is a better alternative than a protracted billing battle. If you have enough cash on hand, consider offering to pay most of the bill immediately. "You can often get the provider to settle for 20 percent less or more, if you'll pay them right away," says Bonnie Sheeren, a medical billing advocate in Houston. As noted in step 3, having information about what providers are typically paid by insurers or Medicare can help bolster your case.

If you have a low income, another option is to ask for a reduced rate based on financial hardship. That strategy worked for Marc and Anne Montgomery of Covington, Ga. Last October, Marc, 40 and a carpenter, needed outpatient surgery for a hernia.

The couple had a short-term health plan through Meritain, which pre-authorized the procedure. But the claim, which totaled \$30,000, was later denied because it was considered not medically necessary. "We were shocked, since the surgery was pre-authorized," says Anne, 33, a market researcher. (Meritain declined to comment on the Montgomerys' case for this article.)

An insurer's pre-authorization doesn't guarantee that claims will be covered. The couple fought the denial but got nowhere. Then in January Anne contacted a medical billing advocate, who advised her to ask the hospital for financial aid based on their low income. "When I told the hospital billing department that the bills would cause significant financial hardship, that opened doors," Anne says. In February the hospital waived its bill, which prompted most of the other medical providers to write off the charges. The couple now has a marketplace plan.

**SMART MOVE:** When negotiating, try to talk to someone with the authority to make a deal, such as a supervisor or the head of the billing department. Reaching the right person may require a lot of persistence, but sometimes it's the only way to make a medical billing problem go away.

unpaid medical bill. Nearly three out of 10 people in the survey said they had unpaid bills sent to collections. Of those, 61 percent said they could not afford to pay, 24 percent didn't realize they owed, and 21 percent lost track of the bill.

The challenges of a complicated and confusing medical billing system can be especially hard on those with serious health issues, because they can face a barrage of bills from hospitals, doctors, and labs. But healthcare providers are affected as well. In a recent JAMA study, researchers from Duke University School of Medicine and Harvard Business School examined data from one academic medical center to assess how much money and time were spent on billing and insurance activities. They found that bill processing for a single visit to a primary care doctor took 13 minutes, a \$20 cost in labor and overhead expenses, or more than \$99,000 per physician annually. Billing for the ER and other specialties was more time-consuming and costly.

## 'I FELT LIKE I WAS BEING GOUGED,'

SAYS **MARCY NEELY** OF CEDAR LAKE, IND., SHOWN WITH HER HUSBAND, **GEORGE**, ABOUT HER SHARE OF A LAB BILL THAT WAS \$1,300 HIGHER THAN WHAT A COMPETING FACILITY CHARGED.



“Administrative expenses, which are largely billing-related, account for 20 percent to 25 percent of U.S. healthcare expenditures,” says David Cutler, a Harvard economics professor and healthcare policy expert. Those hospital administrative costs as a percentage of hospital spending are

twice the level of Canada and far higher than in some other nations, multiple studies show.

Given widespread inefficiencies, it's easy to see how the medical billing process is a major driver of U.S. healthcare spending. One key reason for the high level of spending

## How to Get Help With Your Bills

After a 10-day hospital stay for a heart condition in January 2016, Bill Townsend's hospital bill totaled \$134,000. The 59-year-old comic-book store owner thought his insurer would cover the bulk. But after his deductible, the insurer paid only \$56,000, and the hospital wanted the \$75,000 balance.

Townsend spent months arguing with the insurer and mediating between it and the hospital—including one call when he was put on hold for 90 minutes, then was disconnected. Each time he called, he talked to a different person, he says. “No one could explain the bill,” he says. “I got nowhere.”

Six months later, the hospital sent the debt to collections, and Townsend worried he'd have to drain his savings for a debt he didn't think he owed.

As Townsend learned, medical billing problems can be time-consuming and potentially financially ruinous. Ultimately, Townsend had to hire someone to resolve his bill.

“Too many people don't fight back, or if they do, they don't know how to do it,” says Caitlin Donovan, director of outreach and public affairs at the National Patient Advocate Foundation, which pushes for patient financial protections.

If you can't resolve a medical billing nightmare yourself, enlisting expert help could get results. Here's what to do.

### FILE AN APPEAL

You have a right to a formal appeal with your insurer. The deadline for submitting it will be noted in the initial and subsequent claim denial letters. To bolster your case, include your medical records and letters from your doctors saying why they disagree with the decision to deny. Reaching out to decision-makers and insurance regulators

is the frequency of errors, which requires rebilling and more work. Comprehensive error rate testing from the Centers for Medicare and Medicaid Services last year found that Medicare fee-for-service providers had a 9.5 percent improper billing rate, which led to \$36.2 billion in overpayments. The 10 most recent audits of hospitals by the Department of Health and Human Services Office of the Inspector General found that all had billing error rates from 7 percent to 48 percent.

### Why So Complicated?

By now you may be thinking, why can't we have an efficient, sensible medical billing system? After all, technology has simplified many other financial transactions, such as banking, investing, and paying for ride shares.

To start with, the American healthcare system is a patchwork of plans, government and private, each with its own rules, deductibles, reimbursement levels, and nuances.

The prices people pay for care also vary widely because insurers and providers set their own contracts.

So to determine the correct amount you will owe for a procedure isn't as simple as telling the desk clerk you have, say, United Healthcare Choice Plus. Two people in plans with that same name can be charged different rates by the same doctor or facility, depending on their plan's network or employer or deductible status and negotiated rates, says Missy Conley, director of consumer claims at Medliminal, a firm that reviews insurance claims accuracy for employers, employees, and others.

Also, among these many provider and insurer plans, there's no single standard for electronic record systems, which means they're often incompatible with each other. More than 10 years ago, a study co-authored by Harvard's Cutler found that on average about three claims were denied per physician, per week and needed to

be rebilled. "The administrative burden has only climbed, as insurance policies have become more complex, while the technology has not kept up," Cutler says.

The current medical coding system also presents problems and can result in billing inaccuracies. Each diagnosis or procedure you receive must be given a corresponding alphanumeric code to qualify for reimbursement by insurers. There are more than 150,000 codes in all.

A wrong code can equal a rejected claim. Conversely, the more codes a provider can justify, the higher the reimbursement. That fact has improved the prospects for medical coders, whose U.S. ranks now number 175,000, up from 75,000 in 2009, according to AAPC, a coding trade group.

The administrative strain has led to an overall boon for the medical billing industry. The beneficiaries include in-house billing divisions and independent billing firms, and software companies, among others. A recent study by Grand View Research,

may also help. Send a copy of your dispute letter to the higher-ups of the hospital and insurance company, and report the problem to your state department of insurance or state attorney general. Mention this in your appeal letter.

To find out where to submit a complaint with regulators in your state, use the lookup tool on Consumer Reports' End Surprise Medical Bills site, at [ConsumersUnion.org/insurance-complaint-tool](http://ConsumersUnion.org/insurance-complaint-tool). Also, check out Patient Advocate Foundation's Your Guide to the Appeals Process, at [patientadvocate.org](http://patientadvocate.org), which includes sample appeal letters.

The insurer usually must make a decision within 60 days. If your appeal is denied, ask your insurer for an independent external expert review. The insurer must provide information on how to do that in its final determination letter.

### FIND AN ADVOCATE

If your appeals are denied, seek out an advocacy organization that can help you free of charge. The Patient Advocate Foundation has more than 45 case managers who provide one-on-one counseling. There may

be community resources or disease-specific organizations that provide assistance. For example, the free Heart Valve CareLine sorts out insurance problems for people with heart valve conditions.

You can find such resources on the Patient Advocate Foundation website or download its My Resource Search app. If you are covered by Medicare, contact your State Health Insurance Assistance Program (SHIP), which provides free one-on-one counseling for seniors in every state.

### HIRE HELP

For big bills or complex cases, consider hiring a medical billing advocate. These experts typically charge \$100 or more an hour. Some operate on contingency, taking a percentage of what they save you, usually 25 percent to 35 percent. Look for someone who offers a free initial consultation, get references, and ask about their experience with medical billing, especially with cases similar to yours.

Hiring an expert helped Townsend resolve his bill in March 2017, more than a year after his 10-day

hospitalization for a heart condition. After an initial consultation with Adria Goldman Gross, owner of MedWise Insurance Advocacy, Townsend agreed her fee would be 25 percent of whatever he saved. Gross filed an appeal with the insurer, which didn't budge, then she spoke with the insurance division of the New York State Department of Financial Services. Gross also negotiated with the hospital, which agreed to write off the \$75,000 in charges. After a reduction, Townsend paid Gross \$17,000. He says he is okay with how it turned out. "It could have been a lot more," he says. —Donna Rosato

a market research firm based in San Francisco, estimates that the U.S. outsourcing billing industry pulled in \$2.9 billion in revenues in 2016 and is expected to reach \$7.7 billion by 2025.

Despite these inefficiencies, insurers and providers have little incentive to change the system. After all, these

expenses are simply passed on to consumers through higher premiums and out-of-pocket costs. In 2017, the average annual premium for employer-sponsored coverage for a family of four reached \$18,764, up 55 percent since 2007, according to the Kaiser Family Foundation. And families in

high-deductible plans had to pay on average \$4,448 before coverage kicked in.

It's true that consumers face a deeply broken billing system, but there are ways to minimize the potential for errors—and get problems addressed when they happen. See our advice on page 48 and below.



## WHERE WE STAND: A PATIENT'S FINANCIAL BILL OF RIGHTS

To encourage consumers to be smart and informed about choosing their healthcare, and to bring a degree of fairness to the marketplace, Consumer Reports believes patients must be guaranteed the following basic, common-sense rights. This 12-item Bill of Rights builds on a list of nine recently proposed by Elisabeth Rosenthal, M.D., author of "An American Sickness" (Penguin Books, 2018) and editor in chief of Kaiser Health News.

### The Right to ...

**... easy access to a clear statement of what's covered by your health plan and what's not.**

Federal law already requires this—in a standardized format known as the Summary of Benefits and Coverage, or SBC—but the document is often hard to find. And the growth of high-deductible, short-term, and other limited benefit plans makes it especially vital for consumers to know in advance what charges won't be covered.

**... an itemized and accurate bill in plain English.**

It should include how much the provider charged, how much the insurer is paying, and how much the patient owes. If the insurer isn't paying

for something, the bill should clearly explain why. And no obscure abbreviations.

**... never receive a surprise out-of-network bill.**

Patients are frequently hit with massive out-of-network charges even after visits to in-network physicians and hospitals. Why? Providers often staff their facilities with out-of-network doctors and utilize out-of-network imaging and lab services.

**... accurate information about my insurance plan's provider network.**

Patients need to be able to rely on print and online digital directories to choose doctors and hospitals. If a provider is mistakenly listed as "in network," the insurer should cover any extra out-of-network cost. And doctors should be clearly in network or not—no more letting them cherry pick more lucrative procedures, for example.

**... a stable network.**

Consumers sign up for health insurance one year at a time, so networks should stay the same for at least that long. During that time, providers should be removed only in exceptional circumstances, such as malpractice or retirement.

**... be informed of conflicts of interest.**

Examples: doctors who own a stake in a testing or surgical facility, and hospitals that pay physicians based on how much revenue they generate through procedures or tests.

**... be informed in advance about so-called facility fees.**

Some providers now charge hundreds, even thousands, of dollars extra for overhead—but don't tell the patient until after the visit or procedure. These "facility fees" are sometimes covered by insurance and sometimes not. Patients need that information up front.

**... be informed of lower-cost options.**

Conversations about effective, less expensive procedures and drugs need to be routine and consistent. A 2016 study of 1,800 doctor visits found that cost came up just 30 percent of the time, and doctors offered less expensive options in only half of those cases.

**... be assured that a disputed bill will not be sent to a collection agency.**

Some providers play hardball by quickly sending unpaid bills to debt collectors, even while a bill is being disputed, which can take months or years. Patients

need to be able to question bills without damaging their credit rating—and also have reasonable payment options when a bill swamps their budget.

**... see a price list for elective procedures.**

Reliable estimates, in advance, for non-emergency care would help patients control out-of-pocket spending.

**... be clearly informed about, and given access to, free or reduced-price care programs.**

Many hospitals operate such programs for patients who can't afford to pay—often as required by state law or to qualify for tax exemptions. But the programs are often underutilized because patients aren't aware of them, and programs can have opaque eligibility criteria and complex application processes.

**... no surprise charges for supposedly free preventive services.**

Annual wellness visits are free. But if the provider performs any other service while you're there, or answers specific questions, the visit could be recategorized as "diagnostic" and trigger charges. Providers, insurers, and the federal government should ensure that consumers get the free preventive services they're entitled to.

# ROAD REPORT



STAY  
AHEAD  
OF THE  
CURVE  
WITH  
CR AUTO  
RATINGS,  
NEWS  
& ADVICE™

## THE VITAL STATISTIC

# 73%

Percentage of Americans who say they're afraid to drive in a self-driving car.

Source: AAA.

## TIPS FROM OUR TEST TRACK

### WHEN TO USE SYNTHETIC MOTOR OIL

**Synthetic oil** usually costs twice as much as regular oil. You need to use it only if your owner's manual calls for it, but CR's chief mechanic says it's worth considering if you:



**Make lots of short trips**, live in a region with very

cold winters or very hot summers, or frequently haul heavy loads. All of these can speed the deterioration of conventional oil. While synthetics generally hold up for many more miles, you shouldn't extend oil changes beyond the maximum interval recommended by the manufacturer, typically every six months or year.



**Own an older car** and are concerned about sludge

buildup. Sludge is formed by oxidation and contamination of the oil and can quickly lead to an engine's death. Synthetic oil is less likely to form sludge and acts as a salve for sludge-prone older engines. If you're not sure, ask your mechanic whether your engine is one of them.

## ASK OUR EXPERTS

"I just bought a new car and declined the \$800 protective undercoating that the dealer was urging me to get. Did I make the wrong decision?"

**No.** Cars today are manufactured with corrosion protection, which makes this added treatment unnecessary, though it's profitable for car dealerships. CR recommends that buyers skip it and several other pricey add-ons, including VIN etching, fabric protection, and extended warranties.



## RECALL

### KIA SEDONA MINIVAN

Kia is recalling 106,428 Sedona minivans from the 2015 to 2018 model years because their powered sliding doors can continue closing even when a person or an object is in the way.

**What to do:** Call Kia at 800-333-4542 or visit a Kia dealer or the Recalls page of its website ([kia.com](http://kia.com)) to learn whether your Sedona is one of those being recalled. If it is, Kia says dealers will reprogram the problem module free of charge.

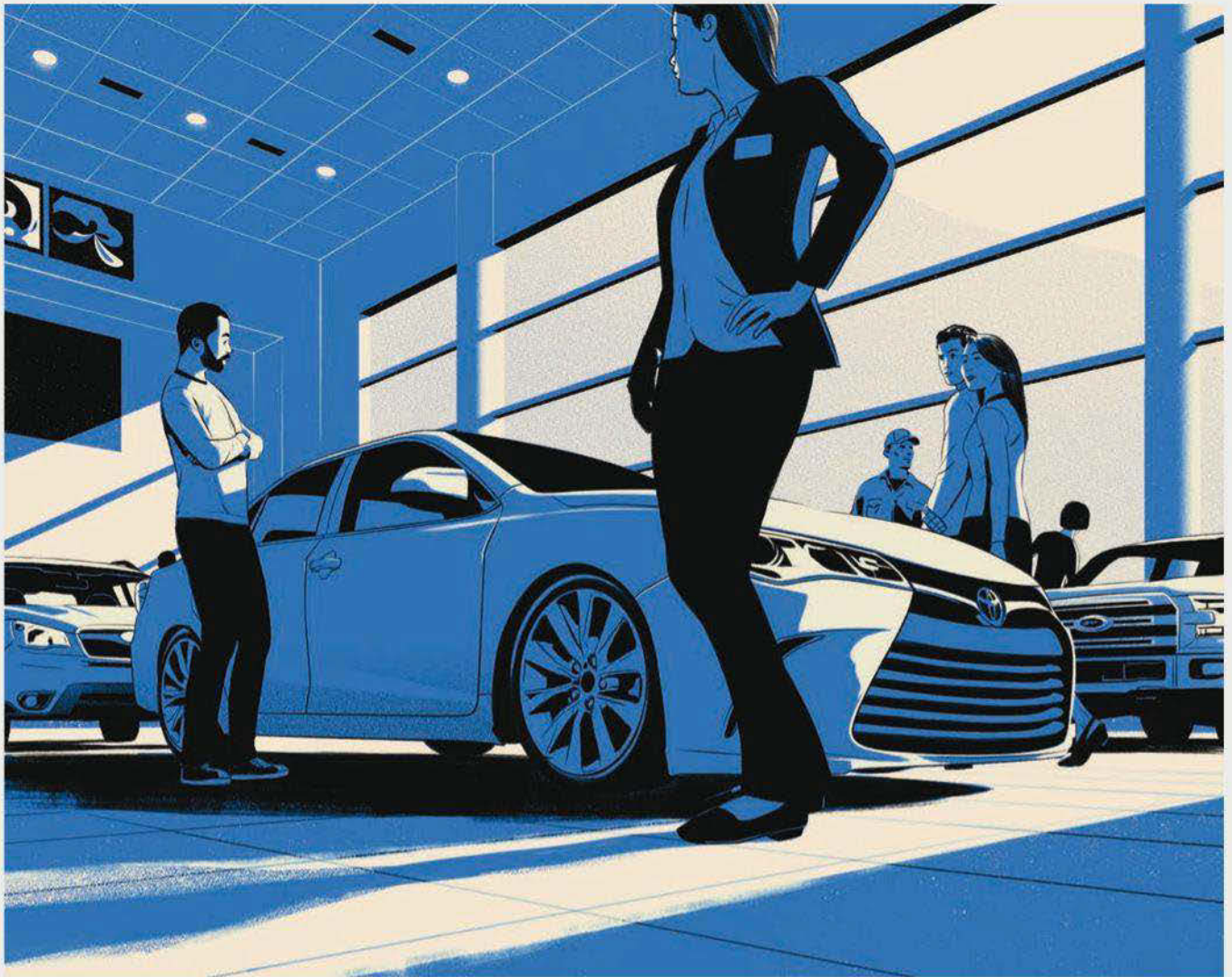

# Get the Most Used Car for Your Money

Hungry for an upgrade but not keen on springing for a new car? Check out our special used-car ratings to make the smartest choice possible.

by **Jeff S. Bartlett**

**THREE-YEAR-OLD CARS ARE** the Goldilocks of the used-auto market. They're new enough that drivers can get contemporary features, safety systems, and updated styling, and expect the vehicles to run well for many more miles. Yet they're old enough that previous owners have borne the brunt of most of the depreciation. In fact, these cars typically sell for about half of what they cost when they were new. And thanks to the popularity of leasing, there's a steady stream of low-mileage, high-quality models for shoppers to choose from.

Our Annual Reliability Survey compiles problems reported by CR

members for more than half a million vehicles. Analysis of the data reveals how reliable an older model has been and allows us to make predictions about how well a new model is likely to hold up.

For this article, CR has adapted the Overall Score we give to new cars into a special Overall Score for 3-year-old used cars. It combines our testing data from when the vehicles were new with reliability and owner satisfaction data from owners who have lived with these cars. This way we can give you the most accurate picture of a vehicle's quality and value for its age.

And things really can change. Some used cars that earned only mediocre road-test scores when they were new may stand out now as attractive options because they boast high reliability and owner satisfaction ratings.

An example is the Toyota 4Runner. Crafted primarily for off-road adventures, this SUV didn't perform well in CR's road tests. But owners tell us they like the way it balances 4x4 capability with on-road drivability—plus, it has top-notch reliability.

Shoppers should look for models that have a high used-car Overall Score, which means they have a good road-test score and respectable reliability and owner satisfaction ratings. Value shoppers should then look for those models whose prices have depreciated more than their competitors'. That may mean a more affordable price and more car for your money now.

Take the Chevrolet Impala. This highly rated large sedan excels as a used-car buy because depreciation makes it the most affordable car in its class. 2015 models start near \$12,000; most rivals start above \$14,000.

We've picked nine of the best values from our used-car ratings, representing choices in several price categories and body styles. Look through our comprehensive ratings charts and you'll find plenty of other good options there as well.

## Used Cars You'll Love

We carefully curated these 2015 models from more than 200. In doing so, we looked at CR test and survey results as well as value (based on how much these cars cost now vs. other models in the class). Each is much less expensive than a comparable new car and promises many reliable years of service. The list isn't exhaustive; there are other good options out there, too. So review our ratings, especially for models that CR has recommended. More information on these—and all rated models—can be found at [CR.org/cars](http://CR.org/cars).

# Under \$15,000



BUDGET RANGE



COMPACT

## 2015 SCION XB

**71**  
OVERALL SCORE

**68**  
ROAD TEST

**23**  
mpg  
FUEL ECONOMY

**\$13,775-  
\$14,200**  
USED PRICE RANGE

RELIABILITY

OWNER SATISFACTION

**CR'S TAKE:** Despite its compact footprint, the xB has a very roomy cabin with a backseat that can genuinely accommodate three adults. The 2.4-liter engine is relatively powerful, but its fuel economy is mediocre. Reliability has been stellar for the 2015 xB, the last year it was made.

**BEST VERSION TO GET:** Not many choices here, only for transmission and wheels.

**WHAT OWNERS SAID:** Survey respondents praised how easy it is to get in and out of, and its comfort, handling, and power. But some said the small gas tank limits its range.



BUDGET RANGE

# \$15,000-\$20,000



78

OVERALL SCORE

MIDSIZE SEDAN  
2015 HONDA ACCORD

85 ROAD TEST  
30 mpg FUEL ECONOMY  
\$15,100-\$22,275 USED PRICE RANGE



RELIABILITY



OWNER SATISFACTION



71

OVERALL SCORE

SMALL SUV  
2015 MAZDA CX-5

74 ROAD TEST  
25 mpg FUEL ECONOMY  
\$14,725-\$19,825 USED PRICE RANGE



RELIABILITY



OWNER SATISFACTION

**CR'S TAKE:** The Accord is comfortable, roomy, and efficient. The 2.4-liter four-cylinder engine returns an excellent 30 mpg overall. And the driver's seat is uniquely suitable for all heights, short to tall, because it can be easily adjusted.

**BEST VERSION TO GET:** Pick the EX-L for its convenience and safety features. Stick with the four-cylinder engine, which is cheaper than the V6 and more efficient.

**WHAT OWNERS SAID:** They praised its acceleration, handling, fuel economy, and value. But noise was a recurring negative.

**CR'S TAKE:** Practical and fun, with a roomy, versatile interior. But a firm ride and loud cabin detract from the experience.

**BEST VERSION TO GET:** Skip the tepid 2.0-liter engine for the more responsive 2.5-liter. The mid-trim Touring offers the best blend of price and equipment. If you stretch to the top-trim Grand Touring, you'll also get advanced safety features.

**WHAT OWNERS SAID:** Feedback on ride varied—pay attention to it when you take a test drive. A typical comment: "This vehicle is very responsive and agile, similar to the Mazda 3 and the MX-5."



BUDGET RANGE

# \$20,000-\$25,000



77

OVERALL SCORE

LUXURY MIDSIZE SEDAN  
2015 LINCOLN MKZ

84 ROAD TEST  
23 mpg FUEL ECONOMY  
\$17,850-\$24,700 USED PRICE RANGE



RELIABILITY



OWNER SATISFACTION



70

OVERALL SCORE

MIDSIZE SUV  
2015 HYUNDAI SANTA FE SPORT

73 ROAD TEST  
23 mpg FUEL ECONOMY  
\$16,100-\$22,125 USED PRICE RANGE



RELIABILITY



OWNER SATISFACTION

**CR'S TAKE:** It has a luxurious, quiet interior, and ride and handling rival some high-end European sports sedans. But rear-seat room is limited.

**BEST VERSION TO GET:** The base model is a good buy, though for a bit more you can get the efficient hybrid. Look for models with the Reserve Equipment Group, which includes blind-spot warning.

**WHAT OWNERS SAID:** Acceleration, fuel economy, handling, comfort, and luxury amenities are high points, though some criticized how difficult the car is to get into.

**CR'S TAKE:** This five-passenger SUV is roomy and comfortable. It has a composed ride and a quiet, well-finished cabin packed with standard features.

**BEST VERSION TO GET:** Stick with the 2.4-liter engine; the 2.0T turbo's power looks better on paper than it works on asphalt. The rearview camera is a must, and it's available with upgrade packages.

**WHAT OWNERS SAID:** "One of the most comfortable vehicles we have ever owned." "Great handling and very responsive power." Comments about ride and seat comfort were mixed.





BUDGET RANGE

# \$25,000-\$30,000



LUXURY MIDSIZED SEDAN  
2015  
INFINITI  
Q70

**90**  
ROAD TEST  
**21 mpg**  
FUEL ECONOMY  
**\$26,075-\$32,125**  
USED PRICE RANGE

**84**

OVERALL SCORE



RELIABILITY



OWNER SATISFACTION



MIDSIZED SUV  
2015  
TOYOTA  
HIGHLANDER

**84**  
ROAD TEST  
**20 mpg**  
FUEL ECONOMY  
**\$22,050-\$32,200**  
USED PRICE RANGE

**81**

OVERALL SCORE



RELIABILITY



OWNER SATISFACTION

**CR'S TAKE:** It was updated for 2015, freshening the appearance and adding safety systems. It's very quick, with a 330-hp V6, and its handling is quite agile, but the ride is firm. Interior quality is top-notch, and the rear seat is roomy.

**BEST VERSION TO GET:** Stick with the standard V6. Models with the Technology package gain safety and driver-assist systems.

**WHAT OWNERS SAID:** Owner satisfaction wasn't a standout overall, but survey respondents thought quite highly of the driving experience. One owner described it as "comfortable and safe."

**CR'S TAKE:** This three-row SUV's appeal lies in its family-friendly nature, frugal mileage, and pleasant driving experience. It handles responsively, absorbs bumps well, and has generous interior space.

**BEST VERSION TO GET:** The XLE is nicely equipped, but you'll have to find a Limited to get advanced safety features.

**WHAT OWNERS SAID:** "We love this car. It has a very quiet and comfortable ride, lots of power, and nice styling inside and outside." "The Highlander is probably the best vehicle we have ever owned." But opinions on seat comfort and noise varied.

## The 2015 Sweet Spot

**Cars evolve over time,** gaining features, efficiency, and safety through redesigns and updates. For car shoppers, a 2015 model can be a meaningful step up without springing for a brand-new one.

Our chart shows the Honda Accord EX from three model years: 2010, 2015 (a 3-year-old used car), and the current 2018 version. We chose a four-cylinder engine and an automatic transmission.

	2010 Honda Accord EX	2015 Honda Accord EX	2018 Honda Accord EX
ORIGINAL MSRP	\$24,630	\$25,030	\$27,470
USED PRICE NOW	\$10,200	\$17,800	N/A
ENGINE/MPG	2.4-liter, 177-hp 4-cyl., 23 mpg overall. 0-60 mph: 9.8 sec.	2.4-liter, 185-hp 4-cyl., 30 mpg overall. 0-60 mph: 7.7 sec.	1.5-liter, 192-hp turbo 4-cyl., 31 mpg overall. 0-60 mph: 7.7 sec.
ENTERTAINMENT	CD player, XM radio, Bluetooth phone, AUX input.	All 2010 features, Pandora compatible, BT audio, USB input.	All 2015 features, plus Android Auto, Apple CarPlay, HD Radio.
SAFETY	<b>Standard:</b> Antilock brakes, electronic stability control, daytime running lights, side-curtain airbags.	<b>Standard:</b> All 2010 features, plus rearview camera. <b>Optional:</b> Forward-collision warning, lane-departure warning.	<b>Standard:</b> All 2015 items, plus adaptive cruise control, auto high-beams, lane-keeping assist. <b>Optional:</b> Blind-spot warning.



BUDGET RANGE

\$30,000+



LUXURY MIDSIZED SEDAN  
2015  
MERCEDES-BENZ E350

**86**  
ROAD TEST

**21 mpg**  
FUEL ECONOMY

**\$29,050-\$33,800**  
USED PRICE RANGE

**76**  
OVERALL SCORE

**↑**  
RELIABILITY

**↓**  
OWNER SATISFACTION

**CR'S TAKE:** The E-Class has long been a benchmark luxury sports sedan, combining a feeling of substance and class with enjoyable handling. Luxury trims have a smooth and cushy ride, but the Sport trim is considerably firmer.

**BEST VERSION TO GET:** The diesel and the 3.5-liter gasoline-powered V6 are both fantastic. Check for models with the Premium I package for comfort features and the Driver Assistance package for safety equipment.

**WHAT OWNERS SAID:** "This has got to be the gold standard for midsize luxury car ride." "With the six-cylinder engine, this car's acceleration is great for quickly getting on the interstate. Smooth and powerful."



LUXURY MIDSIZED SUV  
2015  
LEXUS RX 350

**80**  
ROAD TEST

**21 mpg**  
FUEL ECONOMY

**\$27,275-\$32,500**  
USED PRICE RANGE

**78**  
OVERALL SCORE

**↑**  
RELIABILITY

**↑**  
OWNER SATISFACTION

**CR'S TAKE:** This is a refined, quiet, and plush SUV. It pampers the driver with a comfortable ride, luxurious appointments, and a soothing demeanor. The 3.5-liter V6 provides strong acceleration and an impressive 21 mpg overall.

**BEST VERSION TO GET:** Look for models with the Luxury package, which adds many features, including blind-spot warning.

**WHAT OWNERS SAID:** Most owners said they liked the acceleration, comfort, and handling. "It's like sitting in your living room if your living room had great surround sound and firm, supportive seats." "Easily the most comfortable SUV on the market."

## How to Read Our Ratings

Recommended vehicles did well in testing, have average or better overall reliability, and performed adequately in crash tests (if available). Models with a Poor in the Insurance Institute for Highway Safety's driver-side small and moderate overlap crash tests are not recommended.

**Make, model, and trim or engine** reflect the particular vehicle we tested.

**Price range** shows the span of retail prices for a used 2015 model, reflecting what shoppers can expect to pay.

**Overall Score** combines a vehicle's performance in our road tests, results from our reliability and owner satisfaction surveys, the availability of a front-crash prevention system, and, if available, results from government and insurance industry crash tests.

**Survey results** reflect findings from our recent reliability and owner satisfaction surveys completed by Consumer Reports members.

**Overall reliability** is based on the problems members reported.

**Owner satisfaction** is based on the percentage of surveyed owners who said they would

definitely buy the same car again.

For both surveys, we used CR's expert judgment based on a model's or brand's track record in cases where we had insufficient responses.

**Road-test score** represents the test findings for the particular model when it was new. We buy and test about 50 vehicles each year, driving them for thousands of miles and putting them through more than 50 tests. Some tests, such as those for braking and fuel economy, are empirical and measured with instruments. Those for categories like seat comfort and agility are graded by our experts.

**Overall mpg** is based on CR tests combining a city and highway circuit. The energy consumption of electric vehicles is expressed in a miles-per-gallon equivalent rating (MPGe). Energy consumption for plug-in hybrids is listed in electric and gas modes.

PHOTOS: JOHN POWERS/CONSUMER REPORTS

**Ratings** > **3-Year-Old Used Cars** Our special Overall Score gives you the tools to find the used car that best meets your needs and budget.

Rec.	Make & Model	Overall Score	Price Range	Survey Results		Test Results	
				Overall reliability	Owner satisfaction	Road-test score	Overall mpg
COMPACT ELECTRIC CARS/HYBRIDS							
✓	Toyota Prius	73	\$15,850–\$18,000	↑	↑	75	44
✓	Toyota Prius V	71	\$18,675	↑	↑	73	41
✓	Ford C-Max Hybrid	71	\$12,675–\$14,875	↑	↑	77	37
✓	Chevrolet Volt	69	\$15,200	↑	↑	68	99 <sup>†</sup> /32 <sup>‡</sup>
✓	Toyota Prius C	63	\$13,500	↑	↓	55	43
	Nissan Leaf	56	\$12,525–\$15,250	↑	↓	71	106 <sup>†</sup>
	BMW i3	51	\$16,225–\$19,275	↓	↓	79	139 <sup>†</sup>
	Ford Focus Electric	40	\$14,950	↓	↓	72	107 <sup>†</sup>
CARS: SUBCOMPACT							
✓	Nissan Versa Note	58	\$8,900–\$10,825	↑	↓	61	31
✓	Toyota Yaris	55	\$9,500–\$11,650	↑	↓	47	32
✓	Chevrolet Sonic (1.8L)	54	\$8,550–\$11,900	↓	↓	66	28
✓	Honda Fit	51	\$12,925–\$15,650	↓	↓	67	33
	Kia Rio	50	\$9,050–\$10,375	↓	↓	64	30
	Scion iQ	45	\$9,725	↑	↓	36	34
	Hyundai Accent	44	\$9,725–\$10,150	↓	↓	65	31
	Chevrolet Spark	40	\$8,400–\$9,050	↓	↓	42	31
	Nissan Versa (sedan)	38	\$8,450–\$9,575	↓	↓	56	32
	Ford Fiesta	33	\$7,975–\$15,250	↓	↓	64	33
	Smart ForTwo	26	\$6,875–\$8,275	↓	↓	25	39
	Mitsubishi Mirage	25	\$6,875–\$7,575	↑	↓	29	37
CARS: COMPACT							
✓	Subaru Impreza	75	\$14,425–\$18,975	↑	↓	79	27
✓	Scion xB	71	\$13,775–\$14,200	↑	↑	68	23
✓	Honda Civic (1.8L)	70	\$12,975–\$19,525	↑	↓	71	30
✓	Kia Soul	70	\$12,025–\$16,375	↑	↓	74	26
✓	Mazda3 (2.0L)	69	\$11,350–\$17,325	↑	↓	72	33
✓	Honda Civic Hybrid	67	\$12,975–\$19,525	↑	↓	65	40
✓	Kia Forte (1.8L)	67	\$10,400–\$13,150	↑	↓	78	28
✓	Toyota Corolla	65	\$12,475–\$15,400	↑	↓	71	32
	Chevrolet Cruze (1.8L)	60	\$9,850–\$14,575	↑	↓	69	26

<sup>†</sup> Miles-per-gallon equivalent (MPGe). <sup>‡</sup> Miles per gallon while running on gas engine.

Rec.	Make & Model	Overall Score	Price Range	Survey Results		Test Results	
				Overall reliability	Owner satisfaction	Road-test score	Overall mpg
CARS: COMPACT <i>Continued</i>							
	Hyundai Elantra (1.8L)	59	\$11,900–\$13,200	↓	↓	75	29
	Volkswagen Golf (1.8T)	56	\$10,175–\$29,350	↓	↓	82	28
	Mitsubishi Lancer	53	\$9,575–\$33,625	↑	↓	62	25
	Volkswagen Jetta (1.8T)	48	\$9,950–\$17,075	↓	↓	70	30
	Mini Cooper (3-cyl.)	48	\$14,575–\$25,400	↓	↓	68	31
	Dodge Dart (2.4L)	45	\$9,850–\$13,725	↓	↓	68	27
	Nissan Sentra	41	\$10,975–\$13,200	↓	↓	65	29
	Ford Focus (2.0L)	40	\$9,250–\$17,025	↓	↓	72	28
	Volkswagen Beetle (1.8T)	39	\$11,375–\$18,250	↓	↓	59	27
	Fiat 500L	24	\$9,725–\$12,450	↓	↓	50	27
CARS: MIDSIZED							
✓	Toyota Camry Hybrid	82	\$16,300–\$19,425	↑	↑	87	38
✓	Toyota Camry (4-cyl.)	81	\$14,900–\$19,875	↑	↑	84	28
✓	Chevrolet Malibu (2.5L)	78	\$13,025–\$17,175	↑	↓	81	26
✓	Honda Accord (4-cyl.)	78	\$15,100–\$22,275	↑	↑	85	30
✓	Mazda6	74	\$14,050–\$17,600	↑	↓	79	32
✓	Honda Accord Hybrid	73	\$18,325–\$21,800	↑	↑	77	40
✓	Ford Fusion (1.5T)	73	\$12,375–\$18,850	↑	↓	81	24
✓	Ford Fusion Hybrid	72	\$13,350–\$17,550	↑	↓	80	39
✓	Subaru Legacy (2.5L)	70	\$15,275–\$20,300	↓	↑	89	26
✓	Kia Optima (2.4L)	69	\$13,025–\$20,225	↑	↓	77	25
✓	Hyundai Sonata (2.4L)	67	\$13,200–\$18,600	↑	↓	78	28
	Volkswagen Passat (1.8T)	56	\$10,425–\$17,250	↓	↓	82	28
	Nissan Altima (4-cyl.)	53	\$13,100–\$17,425	↓	↓	77	31
	Chrysler 200 (4-cyl.)	36	\$11,825–\$16,925	↓	↓	63	30
CARS: LARGE							
✓	Chevrolet Impala (3.6L)	79	\$12,050–\$21,400	↑	↑	91	22
✓	Kia Cadenza	76	\$18,200–\$19,650	↑	↑	83	22
✓	Hyundai Azera	74	\$16,200–\$19,300	↑	↓	80	23
✓	Toyota Avalon (V6)	73	\$18,650–\$23,625	↑	↓	81	24

Ratings > 3-Year-Old Used Cars *Continued*

Rec.	Make & Model	Overall Score	Price Range	Survey Results		Test Results	
				Overall reliability	Owner satisfaction	Road-test score	Overall mpg
CARS: LARGE <i>Continued</i>							
✓	Toyota Avalon Hybrid	73	\$20,525–\$23,525	↑	↓	80	36
✓	Buick LaCrosse (V6)	70	\$14,425–\$22,825	↑	↓	76	20
	Chevrolet SS	60	\$32,650	↓	↑	87	17
	Chrysler 300 (V8)	51	\$17,175–\$24,825	↓	↑	84	20
	Dodge Charger (V6)	50	\$17,700–\$46,525	↓	↓	82	22
	Ford Taurus (3.5L)	49	\$14,000–\$23,850	↓	↓	68	21
CARS: LUXURY ENTRY-LEVEL							
✓	Lexus CT 200h	71	\$19,775	↑	↓	65	40
✓	Audi A3 (1.8T)	66	\$16,800–\$27,575	↑	↓	77	27
✓	Acura ILX (2.0L)	64	\$16,200–\$18,300	↑	↓	72	28
	Volkswagen CC (2.0T)	49	\$16,325–\$22,400	↓	↓	78	26
	Buick Verano (2.4L)	49	\$11,100–\$15,900	↓	↓	73	24
	Mercedes-Benz CLA250	42	\$21,975–\$35,450	↓	↓	64	28
CARS: LUXURY COMPACT							
✓	Buick Regal (2.0T)	74	\$15,375–\$21,625	↑	↓	83	24
✓	BMW 328i	66	\$17,575–\$30,200	↑	↓	84	28
✓	Lexus IS 250 (AWD)	66	\$24,125–\$33,475	↑	↓	58	21
	Mercedes-Benz C300 (4MATIC)	55	\$21,050–\$52,400	↓	↓	85	26
	Audi A4 (2.0T Quattro)	53	\$18,600–\$26,250	↓	↓	74	25
	Cadillac ATS (2.0T)	52	\$17,500–\$28,325	↓	↓	79	23
	Volvo S60 T5 Drive-E	51	\$17,675–\$27,725	↓	↓	80	25
	Infiniti Q50 (AWD)	50	\$21,300–\$26,300	↓	↓	75	21
	Acura TLX (2.4L)	50	\$19,425–\$24,825	↓	↓	79	27
CARS: LUXURY MIDSIZED							
✓	Infiniti Q70 (V6)	84	\$26,075–\$32,125	↑	↓	90	21
✓	Lexus GS 350	83	\$28,875–\$39,000	↑	↑	83	21
✓	Infiniti Q70 Hybrid	80	\$26,625	↑	↓	83	25
✓	Lexus ES 350	80	\$23,700–\$25,400	↑	↑	78	25
✓	Lexus ES 300h	79	\$25,075	↑	↑	77	36
✓	Lincoln MKZ (2.0T)	77	\$17,850–\$24,700	↑	↓	84	23

Rec.	Make & Model	Overall Score	Price Range	Survey Results		Test Results	
				Overall reliability	Owner satisfaction	Road-test score	Overall mpg
CARS: LUXURY MIDSIZED <i>Continued</i>							
✓	Lincoln MKZ Hybrid	77	\$19,150–\$24,500	↑	↓	83	34
✓	Mercedes-Benz E350	76	\$29,050–\$33,800	↑	↓	86	21
✓	Audi A6 (3.0T Quattro)	75	\$21,125–\$32,025	↑	↑	90	22
✓	BMW 535i	74	\$23,850–\$55,475	↑	↑	81	23
✓	Audi A7 TDI	74	\$35,650–\$39,475	↑	↓	90	28
	Hyundai Genesis (V6, AWD)	61	\$17,525–\$27,350	↓	↑	89	20
	Cadillac XTS (V6)	58	\$20,175–\$30,425	↓	↓	82	22
	Hyundai Equus (V8)	56	\$26,175–\$28,800	↓	↑	80	19
	Cadillac CTS (V6, AWD)	53	\$20,225–\$41,800	↓	↓	81	21
	Jaguar XF (V6, AWD)	51	\$22,175–\$51,950	↓	↑	80	21
	Acura RLX (V6)	48	\$24,600–\$28,175	↓	↓	75	23
	Lincoln MKS (3.7L)	46	\$20,775–\$23,675	↓	↓	65	20
	Maserati Ghibli SQ4	43	\$21,125–\$38,475	↓	↓	71	19
CARS: ULTRA-LUXURY							
✓	Tesla Model S P85D	92	\$50,600–\$69,975	↑	↑	100	87.1
✓	Lexus LS 460L	78	\$42,050–\$66,700	↑	↑	89	21
	Audi A8 L	65	\$36,325–\$69,525	↓	↑	91	21
	Porsche Panamera S	64	\$48,200–\$67,175	↓	↑	81	20
	BMW 750Li	61	\$33,325–\$40,950	↓	↓	80	18
	Mercedes-Benz S550 (4MATIC)	61	\$53,450–\$98,825	↓	↑	96	18
	Jaguar XJL (V6)	52	\$32,775–\$55,700	↓	↑	82	19
WAGONS (ALL-WHEEL DRIVE)							
✓	Toyota Venza (V6)	77	\$17,425–\$24,000	↑	↑	74	20
✓	Subaru Outback (4-cyl.)	67	\$19,300–\$24,500	↓	↑	82	24
✓	Audi Allroad 2.0T	67	\$26,450–\$32,400	↓	↓	82	22
✓	Honda Crosstour (V6)	63	\$18,050–\$23,925	↑	↓	65	21
	Volvo V60 Cross Country	52	\$17,825–\$22,925	↓	↓	73	21
MINIVANS							
✓	Toyota Sienna (FWD)	73	\$18,275–\$29,925	↑	↑	80	20
✓	Honda Odyssey	71	\$16,950–\$28,850	↑	↓	84	21

Rec.	Make & Model	Overall Score	Price Range	Survey Results		Test Results	
				Overall reliability	Owner satisfaction	Road-test score	Overall mpg
MINIVANS <i>Continued</i>							
	Kia Sedona	65	\$15,650–\$26,250	↑	↓	70	20
	Mazda5	62	\$13,150–\$16,100	↑	↓	83	23
	Nissan Quest	53	\$15,175–\$24,375	↓	↓	79	19
	Ford Transit Connect (2.5L)	52	\$14,925–\$17,775	↓	↓	76	21
	Chrysler Town & Country	43	\$15,525–\$22,900	↓	↓	72	17
	Dodge Grand Caravan	41	\$13,875–\$17,475	↓	↓	72	17
SUVs: SUBCOMPACTS							
✓	Subaru XV Crosstrek (2.0L)	69	\$18,150–\$21,000	↑	↓	74	26
✓	Subaru XV Crosstrek Hybrid	69	\$18,150–\$21,000	↑	↓	74	28
	Mitsubishi Outlander Sport	55	\$11,675–\$15,900	↑	↓	65	23
	Chevrolet Trax	51	\$12,650–\$16,950	↑	↓	55	25
	Jeep Renegade (2.4L)	38	\$13,375–\$18,875	↓	↓	56	24
	Nissan Juke	38	\$13,700–\$18,200	↓	↓	66	24
SUVs: SMALL							
✓	Subaru Forester (2.5L)	78	\$16,550–\$22,000	↑	↑	86	26
✓	Toyota RAV4	75	\$16,525–\$22,350	↑	↓	75	24
✓	Mazda CX-5 (2.5L)	71	\$14,725–\$19,825	↑	↓	74	25
✓	Honda CR-V	64	\$17,125–\$24,850	↑	↓	73	24
	Hyundai Tucson (2.4L)	63	\$14,675–\$18,275	↑	↓	71	22
	Nissan Rogue	60	\$14,725–\$19,800	↓	↓	74	24
	Mitsubishi Outlander (4-cyl.)	53	\$12,775–\$19,225	↑	↓	61	23
	Ford Escape (1.6T)	50	\$13,675–\$19,075	↓	↓	75	22
	Volkswagen Tiguan	46	\$11,975–\$19,200	↓	↓	74	21
	Kia Sportage (2.4L)	40	\$13,825–\$20,550	↓	↓	70	22
	Jeep Compass (2.4L)	36	\$12,450–\$16,750	↓	↓	52	22
	Jeep Cherokee (2.4L)	32	\$14,250–\$22,450	↓	↓	58	22
	Jeep Patriot (2.4L)	30	\$11,375–\$17,175	↓	↓	56	21

Rec.	Make & Model	Overall Score	Price Range	Survey Results		Test Results	
				Overall reliability	Owner satisfaction	Road-test score	Overall mpg
SUVs: MIDSIZED							
✓	Toyota Highlander Hybrid	82	\$34,875	↑	↑	85	25
✓	Toyota Highlander (V6)	81	\$22,050–\$32,200	↑	↑	84	20
✓	Hyundai Santa Fe Sport (4-cyl.)	70	\$16,100–\$22,125	↑	↓	73	23
	Chevrolet Equinox (4-cyl.)	62	\$12,000–\$20,650	↑	↓	68	21
	GMC Terrain (4-cyl.)	62	\$14,125–\$23,725	↑	↓	68	21
	Kia Sorento (V6)	62	\$15,175–\$26,975	↑	↓	77	21
	Toyota 4Runner (V6)	61	\$26,675–\$38,350	↑	↑	55	18
	Hyundai Santa Fe (V6)	59	\$17,850–\$25,050	↓	↓	81	20
	Ford Edge SEL (2.0T)	56	\$16,900–\$26,625	↓	↓	82	21
	Nissan Murano	54	\$18,225–\$27,850	↓	↓	77	21
	Ford Explorer (V6)	49	\$18,875–\$29,700	↓	↓	67	18
	Nissan Pathfinder	49	\$15,925–\$27,375	↓	↓	72	18
	Jeep Grand Cherokee (V6)	49	\$21,625–\$45,900	↓	↓	78	18
	Honda Pilot	49	\$19,575–\$28,700	↓	↓	71	20
	Mazda CX-9	45	\$16,050–\$25,175	↓	↓	77	16
	Dodge Journey (V6)	33	\$13,050–\$19,175	↓	↓	64	16
	Jeep Wrangler Unlimited	18	\$22,500–\$34,075	↓	↑	20	17
SUVs: LARGE							
✓	Toyota Sequoia (5.7L)	63	\$29,850–\$45,200	↑	↓	60	15
✓	GMC Acadia	62	\$19,450–\$28,300	↓	↓	77	16
✓	Chevrolet Traverse	60	\$16,725–\$25,950	↓	↓	77	16
✓	Ford Expedition EL	57	\$23,800–\$39,675	↓	↑	61	14
	Ford Flex (V6)	52	\$17,275–\$26,975	↓	↑	71	18
	Chevrolet Suburban	51	\$30,075–\$43,800	↓	↑	74	16
	Nissan Armada	51	\$23,300–\$34,475	↓	↓	59	13
	Dodge Durango (V6)	51	\$22,125–\$31,825	↓	↑	83	18
	GMC Yukon XL	48	\$32,950–\$46,475	↓	↑	67	16
	Chevrolet Tahoe	46	\$31,125–\$43,225	↓	↓	67	16
	GMC Yukon	46	\$33,150–\$45,950	↓	↓	67	16

Rec.	Make & Model	Overall Score	Price Range	Survey Results		Test Results	
				Overall reliability	Owner satisfaction	Road-test score	Overall mpg
SUVs: LUXURY ENTRY-LEVEL							
✓	Audi Q3	79	\$23,075–\$26,600	↑	↑	77	22
✓	Mini Cooper Countryman S	67	\$15,775–\$26,675	↑	↓	68	26
✓	Buick Encore	66	\$14,150–\$19,325	↑	↓	69	23
	BMW X1 xDrive28i	49	\$18,300–\$24,175	↓	↓	77	23
	Mercedes-Benz GLA250	46	\$22,925–\$36,025	↓	↓	70	26
SUVs: LUXURY COMPACT							
✓	Acura RDX	69	\$22,450–\$25,375	↑	↓	77	22
✓	Porsche Macan S	68	\$43,800–\$55,875	↓	↑	85	19
✓	Lexus NX 200t	68	\$28,125–\$34,200	↑	↓	74	24
✓	Lexus NX 300h	66	\$31,450–\$33,250	↑	↓	71	29
✓	Audi Q5 (2.0T)	63	\$24,100–\$40,000	↓	↓	78	21
	Cadillac SRX	54	\$18,550–\$27,700	↓	↓	67	18
	Mercedes-Benz GLK350	54	\$24,625–\$27,225	↓	↓	79	21
	BMW X3 xDrive28i	53	\$25,150–\$30,825	↓	↓	82	23
	Volvo XC60 T6	50	\$18,475–\$32,525	↓	↓	71	17
	Lincoln MKC (2.3T)	49	\$21,250–\$25,500	↓	↓	71	19
	Land Rover Range Rover Evoque	44	\$27,375–\$37,675	↓	↓	61	21
	Land Rover Discovery Sport	38	\$27,175–\$35,975	↓	↓	58	21
SUVs: LUXURY MIDSIZED							
✓	Lexus RX 450h	82	\$30,150–\$31,450	↑	↑	88	26
✓	Lexus RX 350	78	\$27,275–\$32,500	↑	↑	80	21
✓	Porsche Cayenne (V6)	72	\$46,200–\$68,450	↑	↑	78	19
✓	Acura MDX	72	\$26,225–\$32,325	↑	↓	81	21
✓	Lincoln MKX	69	\$22,325–\$24,225	↑	↓	67	18
✓	BMW X5 xDrive35i	68	\$32,950–\$40,650	↑	↑	84	21

Rec.	Make & Model	Overall Score	Price Range	Survey Results		Test Results	
				Overall reliability	Owner satisfaction	Road-test score	Overall mpg
SUVs: LUXURY MIDSIZED <i>Continued</i>							
✓	Lexus GX 460	67	\$37,750–\$42,275	↑	↑	70	17
	Volkswagen Touareg TDI	53	\$25,800–\$37,950	↓	↓	79	24
	Mercedes-Benz ML350	51	\$30,050–\$55,700	↓	↓	75	18
	Infiniti QX70	51	\$26,400–\$28,550	↓	↓	72	18
	Land Rover Range Rover Sport (3.0L)	48	\$50,425–\$66,850	↓	↓	74	18
	Infiniti QX60 (3.5L)	46	\$26,925–\$29,600	↓	↓	79	19
SUVs: LUXURY LARGE							
✓	Toyota Land Cruiser	71	\$55,925	↑	↑	68	14
✓	Lincoln Navigator	65	\$34,800–\$38,725	↑	↓	70	15
✓	Buick Enclave	65	\$20,000–\$28,250	↓	↓	77	15
	Land Rover Range Rover (3.0L)	50	\$63,150–\$72,500	↓	↓	80	17
	Mercedes-Benz GL350 BlueTec	49	\$40,075–\$65,450	↓	↓	82	20
	Infiniti QX80	48	\$41,900–\$44,225	↓	↓	68	15
	Cadillac Escalade	36	\$42,975–\$56,575	↓	↓	61	16
PICKUP TRUCKS							
✓	Toyota Tundra (5.7L V8)	68	\$20,700–\$38,400	↑	↑	63	15
✓	Toyota Tacoma (V6)	60	\$18,775–\$28,650	↑	↓	49	17
	Ford F-150 XLT (2.7T)	55	\$18,400–\$40,550	↓	↑	76	17
	Chevrolet Silverado 1500 (V8)	55	\$19,025–\$36,025	↓	↓	80	16
	GMC Sierra 1500 (V8)	55	\$16,450–\$36,550	↓	↓	80	16
	Chevrolet Colorado (V6)	46	\$15,875–\$29,300	↓	↓	69	18
	GMC Canyon (V6)	46	\$14,925–\$30,050	↓	↓	69	18
	Nissan Titan (V8)	46	\$19,825–\$29,100	↓	↓	65	14
	Ram 1500 (V8)	45	\$15,150–\$33,425	↓	↓	81	15



## SUBCOMPACT SUVs

## Hyundai Kona

Light on Its Feet, but Loud

**67**

OVERALL SCORE

## ROAD-TEST SCORE 71

**HIGHS** Agility, braking, controls**LOWS** Ride, noise, acceleration**POWERTRAIN** 147-hp, 2.0-liter four-cylinder engine; 6-speed automatic transmission; all-wheel drive**FUEL** 26 mpg on regular fuel**PRICE AS TESTED** \$25,025

**THE KONA IS** playful and inexpensive, making it one of the more appealing subcompact SUVs on the market.

The styling helps it stand out from some of its more ho-hum-looking rivals. Its responsive handling and sharp reflexes make it much more enjoyable to drive than either the Chevrolet Trax or Honda HR-V, two of the Kona's main competitors.

Its ride, on the other hand, is stiff and uncomfortable. And the cabin is loud, on a par with other tiny SUVs. When the Kona is pushed hard to accelerate, which is pretty often, the engine noise becomes intrusive.

Our tested Kona's 2.0-liter engine and six-speed automatic transmission delivered adequate power in most situations. But it took

a long 11 seconds to go from 0-60 mph. We measured 26 mpg overall in our fuel-economy tests, which is good for an AWD SUV but not a standout in this class.

The front seats were comfortable. An affordable options package adds a power driver's seat with two-way adjustable lumbar support, a rare perk for this class.

We like the easy-to-use controls and infotainment system, with its large screen and well-labeled buttons. Android Auto and Apple CarPlay compatibility are standard.

Forward-collision warning and automatic emergency braking aren't offered on the SE and Limited trims. These features are optional on the SEL trim, and they are standard on the top-shelf Ultimate.

## ULTRA-LUXURY CARS

## Lexus LS 500

A Misfire for a Former Leader

**67**

OVERALL SCORE

## ROAD-TEST SCORE 72

**HIGHS** Acceleration, quietness, transmission, driver's seat comfort, fit and finish**LOWS** Controls, rear seat, and ride not up to class standard, small trunk**POWERTRAIN** 416-hp, 3.5-liter V6 turbo engine; 10-speed automatic transmission; all-wheel drive**FUEL** 20 mpg on premium fuel**PRICE AS TESTED** \$103,899

**FOR ALMOST THREE** decades, the Lexus LS has epitomized luxury-car serenity and excellence. With this redesign, however, the sedan's frustrating controls, firmer ride, and tighter interior space could turn off loyal buyers.

Shoppers who want what the LS used to deliver should consider the more satisfying Genesis G90, which we think has stolen the crown for luxury driving experience.

The turbo V6 is strong when drivers push hard on the accelerator, but it doesn't feel powerful in everyday driving.

The ride is steady and controlled, but the impact from bumps is too hard. The LS lacks the plush ride owners should expect.

To its credit, the LS has improved handling and added more responsive steering.

Lexus increased the car's

exterior dimensions, but the sleek styling and lower stance have cut into its usable interior space and made it more difficult to climb into than rivals.

Cabin controls are so complicated that new owners should budget time at the dealership to configure the settings. Using the touchpad to change the audio source, for example, requires drivers to take their eyes off the road to verify their choice. It's also too easy to put the gear selector into Neutral instead of Drive or Reverse.

The driver's seat coddles its occupant, but the heated and cooled seats and heated steering wheel can be adjusted only through the central screen using the touchpad, a tedious and distracting process.

The LS features a robust suite of standard advanced safety features.



COMPACT ELECTRIC CARS

## Nissan Leaf

Low-Energy Effort

75

OVERALL SCORE

**THE NEW LEAF** might seem to be an enticing electric vehicle at first blush. It offers decent battery range and a low entry price. The base model is thousands less than the entry-level Chevrolet Bolt and Tesla Model 3, even before federal or state tax incentives.

And even though this redesign improves on the original, it offers little beyond an attractive price to distinguish it from its EV competitors.

The Leaf's 40-kWh battery gives it a range of 140 miles, which should be enough for most commuters. But that's far less than the Bolt and the Model 3. Shoppers may want to wait for the 2019 Leaf, which will offer a 60-kWh battery with a promised range of over 200 miles.

Our Leaf delivered power smoothly when accelerating

ROAD-TEST SCORE 71

**HIGHS** Low running costs, quietness, power delivery, access, standard automatic emergency braking

**LOWS** Charging times, driving position, agility, ride

**POWERTRAIN** 147-hp electric motor; 1-speed direct-drive transmission; front-wheel drive

**RANGE** 140 miles/8 hrs. (27.5 amps) to charge on 240 volts

**PRICE AS TESTED** \$38,115

from a standstill, but it ran out of oomph at highway speeds.

The mushy handling doesn't inspire driver confidence, and the soft suspension can bottom out, sending a nasty thump to the cabin.

We found the SL's powered driver's seat to be comfortable, helped by the adjustable lumbar support. The Leaf is missing a telescoping steering column to accommodate drivers of all sizes, and the center console rubs against the driver's knee, which can be annoying.

Nissan's optional ProPilot Assist combines adaptive cruise control with lane-centering. It's not designed as a self-driving feature but can be a convenience in stop-and-go traffic. Forward-collision warning and automatic emergency braking are standard.



LUXURY COMPACT CARS

## Tesla Model 3

Fully Electric but Not Fully Baked

77

OVERALL SCORE

**THE MODEL 3** delivers impressive acceleration and handling, a long driving range, and low running costs. But the thrill is tempered by its distracting controls, overly stiff ride, and uncomfortable rear seat. This EV rushes to 60 mph in 5.3 seconds, and in CR testing, our Long Range Model 3 met its EPA rating of 310 miles.

The car's range extended to 350 miles when using Tesla's higher regenerative braking mode. This feature aggressively slows the car to charge the battery when drivers lift off the accelerator. Owners can also take advantage of Tesla's nationwide high-speed charging network during long trips.

We were impressed with the sedan's glued-to-the-road handling and precise steering. But the car doesn't absorb bumps well, and there's a lot of

ROAD-TEST SCORE 82

**HIGHS** Instant power, handling agility, front-seat comfort, low running costs, driving range

**LOWS** Stiff ride, distracting controls, rear seat, charging times

**POWERTRAIN** 258-hp electric motor; 1-speed direct-drive transmission; rear-wheel drive

**RANGE** 310 miles/7 hrs. (40 amps), 12 hrs. (32 amps) to charge on 240 volts

**PRICE AS TESTED** \$59,000

wind noise at highway speeds.

Our initial testing showed long braking distances, which Tesla responded to by improving the performance through an over-the-air update, and now braking is typical for the class.

The front seats and driving position are terrific. But the rear seat is positioned low to the floor, resulting in an uncomfortable knee bend and not enough thigh support.

Nearly every readout and control in the Model 3 is handled using the distracting 15-inch center touch screen, including basic functions such as adjusting the side mirrors.

The optional Autopilot system combines adaptive cruise control and auto-steer, enabling the car to vary its speed and stay in its lane. But we stress that drivers need to remain attentive and engaged.



**Ratings** > **Entry-Level to Luxury** We test about 50 vehicles per year, from almost every category. This month we focus on electric power, luxury trappings, and small haulers.

Recommended	Make & Model	Overall Score	Price	Survey Results		Safety	Road-test score	Overall MPG		Road-Test Results									
				Predicted reliability	Owner satisfaction			Gas	Electric (MPGe)	Acceleration 0-60 mph, sec.	Dry braking 60-0 mph, ft.	Avoidance-maneuver speed, mph	Routine handling	Ride	Noise	Seat comfort front/rear	Controls	Luggage, suitcases+ruffals/cargo volume, cu. ft.	
COMPACT ELECTRIC CARS																			
✓	Chevrolet Bolt Premier	77	\$43,155	↑	↑	Opt.	76		119	6.8	138	53.0	↑	↓	↑	↓/↓	↑	2+0	
✓	Nissan Leaf SL	75	\$38,115	↑	↑	Std./↑	71		112	8.0	141	53.5	↓	↓	↑	↑/↓	↑	3+0	
	BMW i3 Giga Rex	66	\$50,450	↓	↓	Opt.	79	29	139	7.5	131	55.0	↑	↑	↑	↑/↓	↓	1+1	
	Ford Focus Electric	51	\$40,990	↓	↓	NA	76		107	10.2	140	52.5	↑	↑	↑	↑/↓	↑	1+1	
LUXURY COMPACT CARS																			
✓	Audi A4 Premium Plus	85	\$48,890	↑	↑	Std./↑	88	27		6.3	135	53.5	↑	↑	↑	↑/↓	↓	2+2	
✓	BMW 330i xDrive	78	\$51,745	↑	↓	Opt.	86	26		6.9	129	55.0	↑	↑	↑	↑/↓	↓	2+2	
✓	Tesla Model 3 Long Range	77	\$59,000	↓	↑	Std./↑	82		130	5.3	133	55.0	↑	↓	↓	↑/↓	↓	2+2	
	Infiniti Q50 3.0t Luxe (AWD)	67	\$48,775	↓	↓	Opt.	85	22		5.7	126	56.0	↑	↑	↑	↑/↓	↓	2+1	
	Lexus IS 300 (AWD)	67	\$48,149	↑	↓	Std./↑	56	20		6.5	139	53.0	↑	↓	↑	↑/↓	↓	2+1	
	Mercedes-Benz C300 (4MATIC)	66	\$47,560	↓	↓	Std./↑	85	26		6.8	136	55.5	↑	↑	↑	↑/↓	↓	2+1	
	Jaguar XE Premium (25t AWD)	50	\$47,378	↓	↑	Opt.	69	25		7.7	133	53.0	↑	↑	↑	↓/↓	↓	1+2	
	Alfa Romeo Giulia Ti (AWD)	48	\$48,890	↓	↑	Opt.	70	27		6.7	136	53.0	↑	↑	↑	↑/↓	↓	1+2	
ULTRA-LUXURY CARS																			
✓	Tesla Model S P85D	94	\$127,820	↑	↑	Std./↑	100		87	3.5	118	55.5	↑	↑	↑	↑/↓	↓	4+3	
✓	BMW 750i xDrive	86	\$110,645	↑	↓	Opt.	99	21		5.3	131	52.5	↑	↑	↑	↑/↑	↓	2+4	
✓	Genesis G90 Premium (3.3T, AWD)	81	\$71,550	↓	↑	Std./↑	89	18		6.0	130	52.0	↑	↑	↑	↑/↑	↑	3+0	
✓	Mercedes-Benz S560 (4MATIC)	79	\$114,475	↓	↑	Std./↑	96	18		5.1	128	51.0	↑	↑	↑	↑/↑	↓	2+3	
	Lexus LS 500 (AWD)	67	\$103,899	↓	↑	Std./↑	72	20		6.0	136	51.5	↑	↑	↑	↑/↑	↓	2+1	
SUBCOMPACT SUVs																			
✓	Subaru Crosstrek Premium	80	\$25,905	↓	↑	Opt.	87	29		10.2	125	54.5	↑	↑	↑	↓/↑	↑	27.5	
✓	Nissan Rogue Sport SV (2018.5)	70	\$25,655	↓	↓	Std./↑	72	26		10.3	134	52.5	↑	↑	↑	↑/↓	↑	24.5	
✓	Hyundai Kona SEL (2.0L)	67	\$25,025	↓	↑	Opt.	71	26		11.1	129	56.0	↑	↓	↓	↑/↓	↑	22.5	
✓	Honda HR-V LX	67	\$22,045	↑	↓	NA	66	29		10.5	132	55.0	↑	↓	↓	↓/↑	↑	32.0	
✓	Mazda CX-3 Touring	65	\$25,800	↑	↓	Std./↑	64	28		9.6	135	53.5	↑	↓	↓	↓/↓	↓	18.0	
	Ford EcoSport SES (2.0L)	57	\$28,130	↓	↓	NA	61	24		10.7	132	54.5	↑	↓	↓	↓/↓	↑	22.5	
	Chevrolet Trax LT	56	\$25,560	↑	↓	Opt.	55	25		10.8	130	54.0	↓	↓	↓	↓/↓	↓	26.0	
	Jeep Renegade Latitude	44	\$27,525	↓	↓	Opt.	56	24		9.9	130	51.5	↓	↓	↓	↓/↓	↑	30.5	
	Fiat 500X Easy	35	\$26,600	↓	↓	Opt.	50	23		9.8	130	52.5	↓	↓	↓	↓/↓	↑	19.5	

**HOW WE TEST:** Recommended models did well in our **Overall Score**, which factors in **Road-Test Results**, **Predicted reliability**, **Owner satisfaction**, and **Safety**, which includes crash-test results and the

availability of front-crash prevention features, such as forward-collision warning and automatic emergency braking at city or highway speeds. For these systems, NA means no such system is offered; Opt. means

it's available on some versions but not necessarily on the one we tested; and models with standard systems are rated from ↓ to ↑ based on how many of these features are standard. We also deduct points

from the **Overall Score** if a vehicle's shifter lacks fail-safes or is difficult to operate. Readers with a Digital or All-Access membership can go to [CR.org/cars](http://CR.org/cars) for complete, up-to-date ratings.

**A**

- Air conditioners Jul 18, 17
- lowering cooling costs Jul 18, 19
- Air filters, home changing & cleaning Nov 17, 12
- Air fryers Jun 18, 15
- Air purifiers Nov 17, 8
- costs Nov 17, 10
- Amazon Prime Jul 18, 14
- Arsenic in rice Mar 18, 5
- Assisted living Oct 17, 28
- contract details Oct 17, 34
- finances Oct 17, 36
- insurance Oct 17, 40

**AUTOMOBILE RATINGS**

- Alfa Romeo Giulia Nov 17, 62
- Alfa Romeo Stelvio Dec 17, 62
- Audi Q5 Nov 17, 63
- BMW X2 Aug 18, 63
- BMW X3 Mar 18, 58
- Buick Enclave Mar 18, 58
- Buick Regal May 18, 59
- Chevrolet Equinox Diesel Jul 18, 62
- Chevrolet Traverse Feb 18, 59
- Chrysler Pacifica Hybrid Oct 17, 63
- Ford EcoSport Jun 18, 59
- Ford Expedition May 18, 58
- GMC Terrain Mar 18, 59
- Honda Accord Feb 18, 58
- Honda Civic Si Jan 18, 58
- Honda Clarity Jul 18, 62
- Honda Odyssey Oct 17, 63
- Hyundai Accent Jul 18, 63
- Hyundai Elantra GT Jun 18, 59
- Hyundai Kona Sep 18, 63
- Hyundai Sonata Feb 18, 58
- Infiniti QX50 Aug 18, 64
- Jaguar E-Pace Aug 18, 63
- Jaguar XE Nov 17, 62
- Jeep Wrangler Jun 18, 58
- Kia Rio Jul 18, 63
- Kia Stinger May 18, 59
- Land Rover Discovery Nov 17, 63
- Land Rover Range Rover Velar Mar 18, 59
- Lexus LS 500 Sep 18, 63
- Lexus RX L Jun 18, 58
- Lincoln Navigator May 18, 58
- Nissan Leaf Sep 18, 64
- Nissan Rogue Sport Jan 18, 59
- Subaru Crosstrek Jan 18, 59
- Tesla Model 3 Sep 18, 64
- Toyota Camry Dec 17, 63
- Hybrid Feb 18, 59
- Toyota C-HR Jan 18, 58
- Toyota Mirai Oct 17, 62
- Volkswagen Atlas Oct 17, 62
- Volkswagen Tiguan Dec 17, 62
- Volvo XC40 Aug 18, 64
- Volvo XC60 Dec 17, 63

**AUTOMOBILES & AUTO EQUIPMENT**

- Auto insurance discrimination Mar 18, 5
- Backup cameras Aug 18, 5
- Best & worst lists Apr 18, 28
- Best vehicles for road trips Jul 18, 39
- Brand Report Card Apr 18, 26
- Buying new vs. used Feb 18, 50
- Coming in 2018 Apr 18, 35
- Driver data privacy Jun 18, 44
- Emergency kit preparation Jul 18, 30
- Financing Dec 17, 60
- Fuel economy Apr 18, 10
- standards Jul 18, 5
- technological advances Apr 18, 13
- time line Apr 18, 14
- Gas, finding cheapest Jul 18, 38
- High-tech vehicles Jun 18, 44
- In-car entertainment systems Oct 17, 54
- audio streaming Oct 17, 57
- Bluetooth phone calls Oct 17, 58
- in-dash navigation Oct 17, 56
- most and least distracting Jan 18, 53
- voice commands Oct 17, 59
- Intelligent high beams Jan 18, 12
- Owner satisfaction Feb 18, 48
- Profiles, 2018 Apr 18, 47
- Ratings, 2018 Apr 18, 37
- Reliability Apr 18, 85
- new cars Dec 17, 52
- Roadside assistance Jul 18, 34
- Safety systems May 18, 12
- Self-driving cars Oct 17, 5; Dec 17, 5; Jun 18, 5
- Sunroofs, exploding Dec 17, 30; Feb 18, 5
- Tires Nov 17, 52
- best by region Jan 18, 16
- Top Picks for 2018 Apr 18, 19

- Trucks Apr 18, 24
- safety Aug 18, 58
- Used cars Apr 18, 81
- best 3-year-old models Sep 18, 54
- flood damage Feb 18, 52
- Vehicle-to-vehicle communication Jun 18, 44
- Winter driving Nov 17, 52

**B-D**

- Banks**
  - customer satisfaction May 18, 14
- Beds-in-a-box Mar 18, 30
- Behavior taxes Oct 17, 48
- Bicycle helmets Jun 18, 11
- Bitcoin May 18, 15
- Blenders**
  - Vitamix vs. Kalorik Nov 17, 39
- Breakfast**
  - fast-food Aug 18, 42
- Cable TV Aug 18, 30
- savings Aug 18, 36
- Cameras Jun 18, 23
- Carpet cleaners Jun 18, 18
- Cell phones Jan 18, 24
- how to buy Jun 18, 14
- insurance Jun 18, 50
- iPhone X vs. iPhone 8 Feb 18, 13
- refurbished Jun 18, 56
- repairing cracked screens Jun 18, 54
- service providers Jun 18, 50
- Chicken**
  - nutritional value Oct 17, 44
- Cleaning equipment**
  - carpet cleaners Jun 18, 18
  - vacuums
    - for allergy sufferers Nov 17, 13
    - belts Sep 18, 18
    - robotic Jan 18, 18
- Cleaning tips**
  - carpet stains Jun 18, 21
  - curtains Jul 18, 12
  - laptops Sep 18, 15
  - pillows Jun 18, 12
- Coffee**
  - add-ins Mar 18, 13
  - beans and equipment Oct 17, 8
  - packaging claims Oct 17, 10
- Cold & flu Jan 18, 30
- Consumer data security Dec 17, 5
- Consumer Financial Protection Bureau May 18, 5
- Cordless drills Dec 17, 8
- attachments Dec 17, 12
- components Dec 17, 11
- Crackers Jan 18, 42
- toppings Jan 18, 45
- Credit cards
  - using while traveling Jul 18, 38
- Credit data privacy May 18, 5
- Credit freezes Sep 18, 7
- Data, financial
  - protection Jun 18, 16
- Data breaches Dec 17, 5
- Equifax Feb 18, 5
- Dishwashers Sep 18, 36
- time line Sep 18, 16
- Doctors**
  - degrees Mar 18, 48
  - primary care physicians Mar 18, 53
  - specialists Mar 18, 55
- Door locks Mar 18, 14
- Driving
  - distracted Jan 18, 48
  - phone anti-distraction features Jan 18, 54
  - safety around trucks Aug 18, 60
  - winter Nov 17, 52
- Drones Mar 18, 18
- Drugs**
  - prices Jan 18, 5; May 18, 5, 40; Jun 18, 5
  - lowering May 18, 44
  - shopping around May 18, 49
- Dryers Aug 18, 48

**E-G**

- Earphones, wireless** May 18, 24
- Egg labeling Feb 18, 12
- Equifax hack restitution Feb 18, 5
- Farmers markets Sep 18, 35
- Fast-food breakfasts Aug 18, 42
- Fees
  - “What the Fee?!” campaign Sep 18, 7
- Financial data protection Jun 18, 16
- Fire extinguisher use Feb 18, 11

- Flexi-fridges Feb 18, 14
- Food**
  - antibiotics in labeling Nov 17, 30
  - store-prepared Jul 18, 5
  - Jan 18, 15
  - Food recall location details Dec 17, 5
  - Foodborne illness tracking Sep 18, 7
  - Fraud victim protection Jan 18, 5
  - Frozen pizza Feb 18, 34
  - Frozen vegetables May 18, 52
  - cooking tips May 18, 55
  - Furniture tipping hazards Jan 18, 5; May 18, 21
  - Grain bowls Oct 17, 42
  - Green juices Aug 18, 13
  - Grills Mar 18, 11; May 18, 28; Jul 18, 22
  - accessories Jul 18, 24
  - buying at Home Depot & Lowe’s May 18, 34
  - care and cleaning Jul 18, 26
  - food safety Jul 18, 23
  - lump charcoal vs. briquettes Jul 18, 27
  - replaceable parts May 18, 32

**H-K**

- Headphones, wireless** May 18, 24
- Healthy eating Nov 17, 18; Sep 18, 26
- antibiotics in food Nov 17, 30
- drinks Sep 18, 34
- fat Nov 17, 27
- fish Sep 18, 32
- fruits & veggies Sep 18, 31
- gluten Nov 17, 32
- leafy greens Sep 18, 28
- packaging claims Nov 17, 23
- promoting in children Nov 17, 22
- salt Nov 17, 24
- alternatives to sugar Sep 18, 16
- Hearing aids Nov 17, 5
- Heart surgery Jul 18, 50
- common procedures Jul 18, 52
- hospital ratings Jul 18, 56
- questions to ask Jul 18, 54
- Helmet, bicycle Jun 18, 11
- Home care Dec 17, 40
- Home remodeling**
  - for curb appeal Jun 18, 34
  - elder-friendly upgrades Dec 17, 44
- Hot car child protection Nov 17, 5
- Insect repellents Aug 18, 28
- Instant Pot tips Mar 18, 16
- Insurance**
  - smartphone Jun 18, 50
- iPhone X vs. iPhone 8 Feb 18, 13
- Kitchen equipment**
  - air fryers Jun 18, 15
  - appliance suites Oct 17, 20
  - best bundles Oct 17, 22
  - for healthy cooking Nov 17, 34
  - multi-cookers Nov 17, 38

**L-P**

- Laundry**
  - detergent safety alert Oct 17, 18
  - machines Aug 18, 51
  - Samsung vs. LG Oct 17, 14
  - room renovation Aug 18, 48
  - time line Aug 18, 14
- Lawn mowers Jun 18, 38
- time line Jun 18, 12
- Lightbulbs Feb 18, 16
- Mattresses Mar 18, 22; Jun 18, 13
- beds-in-a-box Mar 18, 30
- types Mar 18, 28
- warmth retention Aug 18, 15
- Media mergers Mar 18, 5
- Medical billing Sep 18, 44
- Microsoft hardware
  - poor predicted reliability Nov 17, 16
- Mowers Jun 18, 38
- time line Jun 18, 12
- Multi-cookers Nov 17, 38
- Instant Pot tips Mar 18, 16
- Music streaming services Sep 18, 14
- Naturopathic medicine Mar 18, 56
- Net neutrality Jun 18, 5
- Nonstick pans Jan 18, 13
- Ovens Jan 18, 15
- Paints**
  - exterior Jun 18, 34
- Passwords Sep 18, 17
- Patient safety May 18, 5
- Phone bills Aug 18, 5

- Photos**
  - digitization Jul 18, 58
  - print-making services Dec 17, 14
- Pillows, cleaning Jun 18, 12
- Pink tax Jul 18, 5
- Pizza**
  - frozen Feb 18, 34
  - unhealthy chain options Feb 18, 37

**R-S**

- Recall reform Nov 17, 5
- Refrigerators Aug 18, 18
- capacity Aug 18, 14
- flexi-fridges Feb 18, 14
- ideal food arrangement May 18, 13
- where to buy Aug 18, 20
- Retirement Mar 18, 42
- healthcare expenses Mar 18, 47
- unexpected Mar 18, 45
- Road trips Jul 18, 28
- pet care Jul 18, 35
- snacks Jul 18, 37
- tech tips Jul 18, 32
- Robocalls Oct 17, 5; Aug 18, 5
- Robovacs Jan 18, 18
- Scams Jun 18, 26
- classic scams Jun 18, 30
- combating Jun 18, 32
- who gets scammed Jun 18, 29
- Shopping**
  - for appliances Jul 18, 15
  - farmers markets Sep 18, 35
  - online Dec 17, 20
  - haggling Feb 18, 27
  - paying less Feb 18, 24
- Smart TVs
  - privacy May 18, 22
- Smartphones Jan 18, 24
- how to buy Jun 18, 14
- insurance Jun 18, 50
- iPhone X vs. iPhone 8 Feb 18, 13
- refurbished Jun 18, 56
- repairing cracked screens Jun 18, 54
- service providers Jun 18, 50
- Smartwatches
  - Apple Watch 3 vs. Fitbit Versa Aug 18, 16
- Snack crackers Jan 18, 42
- toppings Jan 18, 45
- Space heaters Jan 18, 14
- Stain removal, carpet Jun 18, 21
- Stains Jun 18, 34
- Stem cell treatments Mar 18, 36
- Strollers Feb 18, 15
- Student debt Oct 17, 5; Feb 18, 5
- Sunscreens Jul 18, 42
- bargains Jul 18, 46
- time line Jul 18, 12

**T-U**

- Television sets**
  - 4K Nov 17, 44
  - audio setup for easier hearing Jul 18, 11
  - best deals Feb 18, 40
  - how to shop for Nov 17, 49
  - satisfying lower-priced models Nov 17, 47
  - smart
    - privacy May 18, 22
- Tick protection Jul 18, 13
- Toilets Feb 18, 18
- wall-mounted Feb 18, 21
- TV antennas Aug 18, 35
- TV streaming Aug 18, 40
- cable replacement services Aug 18, 38
- devices Aug 18, 41
- Vacuums**
  - for allergy sufferers Nov 17, 13
  - belts Sep 18, 18
  - robotic Jan 18, 18
- Veggie burgers Sep 18, 13
- Video**
  - 4K content availability Nov 17, 46
  - digitization Jul 18, 58
  - streaming devices Feb 18, 43
- Voice assistant
  - Alexa Jan 18, 11

**W**

- Washing machines Aug 18, 48
- WiFi
  - signal strengthening May 18, 11
- Winter driving Nov 17, 52

# Signs of the Times

These ads and billboards should not be taken at their word

## A Bedtime Offer You Can't Refuse

These sheets must be guaranteed to make you lose sleep.  
Submitted by Michael Consolo, via email

Ea., Assorted Colors, Queen or King  
(Where Available, While Supplies Last)

# 1,000 Threat Count Sheet Set

# 19.99

**YOU SAVE 30.00**

price PLUS Club  
Limit 4 Per Variety

**Drop Your Pants Here** →

VERY DROP-OFF INCL

Top Brand Detergents  
Shirts On Hangers  
Black  
Coke  
Paper  
All U  
MO

**Drop Your Pants Here** →

PLUS ALL YOUR OTHER LAUNDRY  
20% OFF MON-THURS

↑ DROPOFF, PICKUP WINDOW

## Funny Business

Mom warned us about laundromats like you.  
Submitted by Andrew Watz, Queens, NY

## Time Flies

Perfect for those who are truly impatient.  
Submitted by Megan Fotheringham, Alexandria, VA

**ANTIQUE TABLES**  
MADE DAILY  
TUES-SAT 10-5

**FISHING & CRABBING AREA**

**NO FISHING & CRABBING**

## Catch Me if You Can

If the fish aren't biting today, move 2 feet to your left.  
Submitted by Steve Furedy, State College, PA



Be on the lookout for goofs and glitches like these. Share them with us—by email at [SellingIt@cro.consumer.org](mailto:SellingIt@cro.consumer.org) or by mail to Selling It, Consumer Reports, 101 Truman Ave., Yonkers, NY 10703—and we might publish yours. Please include key information, such as the publication's name and date.

# Car shopping?

## Get a deal. Without the ordeal.



### Finding the perfect set of wheels is easier than you think

- **Choose new or used:** Check reviews, ratings, and reliability data
- **Save:** With competitive, haggle-free, up-front pricing
- **Know:** All about financing, safety features, insurance, tires, and car seats

**LET'S GO**  
[cr.org/buyacar](https://www.consumerreports.org/buyacar)

**CR** ConsumerReports®

